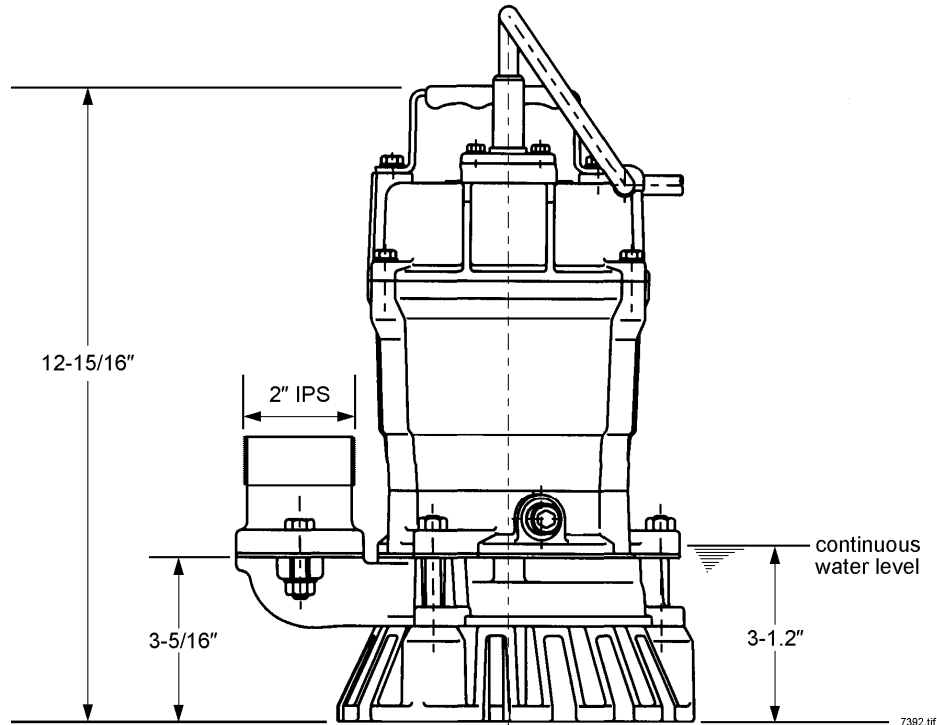

MATERIAL STANDARD**CAST IRON PUMP****1. Scope**

This specification is for 110V-120V submersible centrifugal pumps intended for use in underground transformer vaults. The effluent to be pumped consists of water mixed with silt, small amounts of sand and gravel (up to 3/8" diameter), detergents, and other materials typical of what might be washed off city streets. The pumps shall comply with the latest revisions to all applicable ANSI, NEMA, NEC, MIL-P-28607 Type III, Class III, and UL requirements, except where modified by this specification. The motor shall be rated single-phase, 110-120V, 1 phase, 60 Hz.

2. Industry Standards

Cast iron pumps shall meet the applicable requirements of the latest industry standards:

NEMA MG-1 – Motors and Generators

MIL-P-28607 – Military Specification, Pump, Submersible

ANSI

National Electrical Code

3. Performance

The 1/2-hp pump shall have a minimum capacity of 45 U.S. gallons per minute at a 10-foot head. The maximum head shall not be less than 34 feet. The pumps shall be capable of passing suspended solids (up to 1" in diameter) equal to 30% by volume of the water being pumped without clogging the impeller or pump passages.

STANDARDS COORDINATOR

John Barnett

STANDARDS SUPERVISOR

John Barnett

UNIT DIRECTOR

John Nierenberg

4. Construction**4.1 Materials**

The pump housing shall be cast iron. The rotor shaft shall be of 403 stainless steel. The semi-vortex impeller may be corrosion-resistant steel or urethane rubber material. If the impeller is not corrosion-resistant steel, the material must be pre-approved by engineering. All external fasteners shall be stainless steel.

4.2 Motor

The motor shall be rated for 115V, single-phase, 60 Hz., intermittent operation and thermally protected by an automatic reset overload protection device. The motor locked rotor rating shall not exceed NEMA Code M. The motor shall have permanently lubricated sealed bearings at both ends of the shaft (bushings are unacceptable). The motor shall be split-phase without a capacitor.

4.3 Outlet/Inlet

The 1/2-hp pump shall have a straight outlet with 2" NPT female threads. The inlet base shall be cast iron.

4.4 Power Cord

The power cord shall be 16 to 20 feet in length and shall be UL approved for submersible use.

5. Approved Manufacturer

<u>Stock Number</u>	<u>Horsepower</u>	<u>Approved Manufacturer</u>
739290	1/2	Tsurumi HS2-4S-62