

STUD BOLTS FOR LINE POST INSULATORS

Long and short bolts shall be interchangeable in the insulators. All parts shall be hot-dip galvanized per ASTM A-153 (2 mils min.).

Long stud bolts shall be furnished with a 2-1/4" x 2-1/4" square washer, a lock washer, a square nut, and a helical spring washer. The helical spring washer shall have a section width of 0.234" and a section thickness of 0.188" meeting ANSI B18.21.1. See City Light Material Standard 5842.5, Stock No. 584267.

Short stud bolts shall be furnished with two lock washers and a hex nut.

It shall be the Bidder's responsibility to update and/or maintain the referenced manufacturer's catalog numbers shown. A written explanation must accompany each bid if different from the numbers shown.

Stock Unit: EA

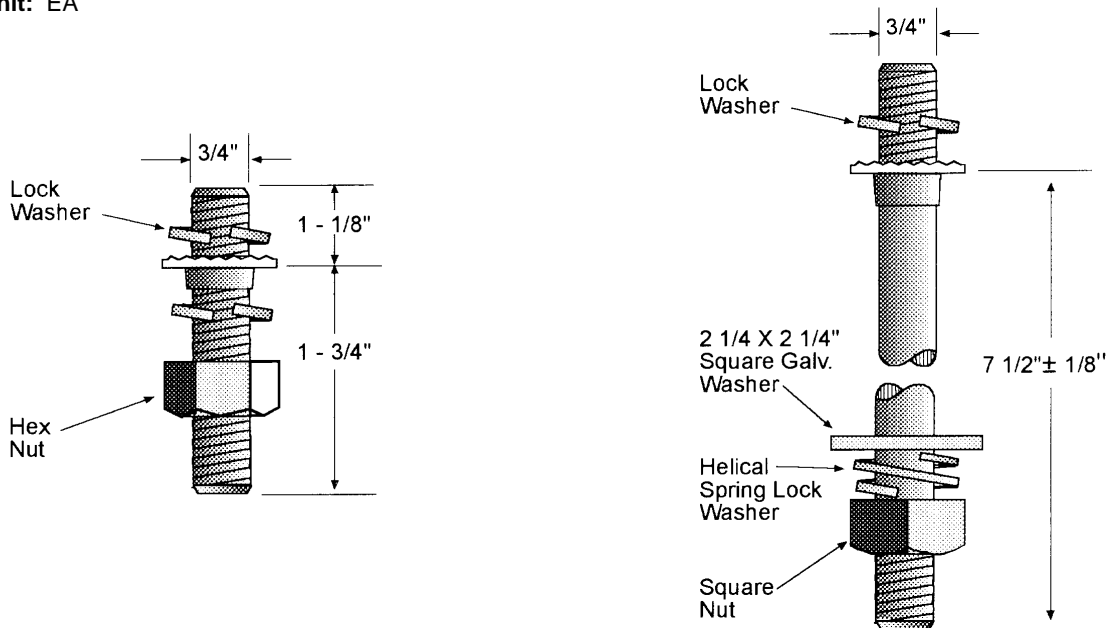

Stock No.	Size	Approved Manufacturers						
		Hubbell/ Chance	Joslyn	Lapp	Locke	Newell	TIFFIN/ Porc. Prod	Victor
696826	Short Stud	DF19M3	J25249.1	10186	27542	87573	6502	72088
696828	Long Stud	Obsolete	J25250.34	-	-	87574 S	6512- 7-1/2 S	72087 S

Note: S = Special; coil spring washer in place of standard locknut.

Standards Coordinator
Robin Byun

Standards Supervisor
John Shipek

Unit Director
Darnell Cola

Robin Byun

John Shipek

Darnell Cola