

Arm Assemblies, Decorative, Aladdin

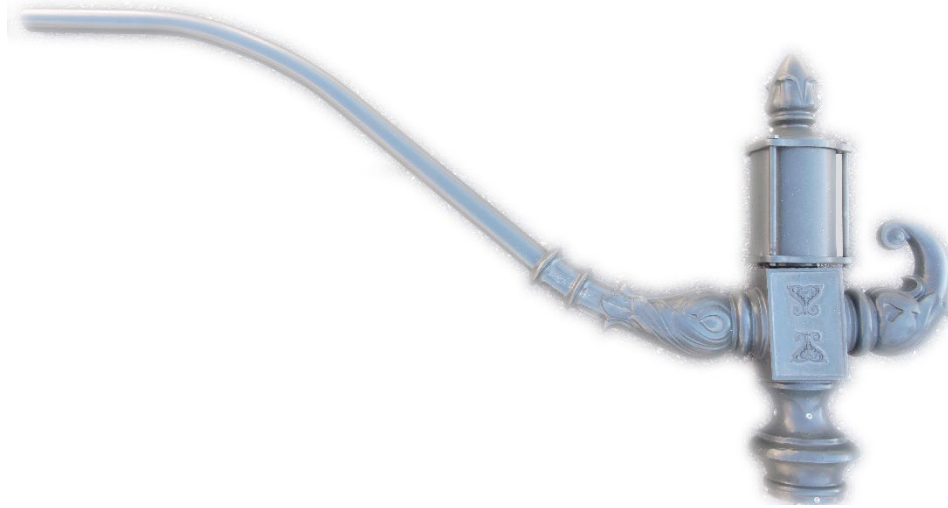

1. Scope

This standard covers the requirements for Aladdin decorative arm assemblies.

This standard applies to the following Seattle City Light (SCL) stock numbers:

Stock No.	Description
012771	Aladdin Decorative Arm, 6-ft
013536	Aladdin Decorative Arm, 8-ft

2. Application

Aladdin arm assemblies are used in the following City of Seattle lighting districts: Pioneer Square, Central Business District, Westlake Avenue and Mercer Corridor.

Aladdin arm assemblies are used with Chief Seattle ornamental steel streetlight poles. See SCL 5756.22.

3. Industry Standards

Aladdin arm assemblies shall meet the applicable requirements of the latest revision of the following industry standards:

AASHTO; Standard Specifications for Structural Supports for Highway Signs, Luminaires, and Traffic Signals

Standard Coordinator
Quan Wang

Standards Engineering Supervisor
John Shipek

Division Director
Andrew Strong

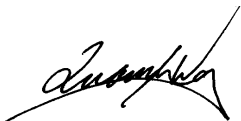

ASTM A 153; Standard Specification for Zinc Coating (Hot-Dip) on Iron and Steel Hardware

ASTM A 307; Standard Specification for Carbon Steel Bolts and Studs, 60,000 PSI Tensile Strength

ASTM B 117; Standard Practice for Operating Salt Spray Apparatus

ASTM D 2247; Standard Practice for Testing Water Resistance of Coatings in 100% Relative Humidity.

ASTM B26-12; Standard Specification for Aluminum Alloy Sand Castings

ASTM 123; Standard Specification for Zinc (Hot-Dip Galvanized) Coatings on Iron and Steel Products

ASTM F2329; Standard Specification for Zinc Coating, Hot-Dip, Requirements for Application to Carbon and Alloy Steel Bolts, Screws, Washers, Nuts, and Special Threaded Fasteners

ASTM F1554; Standard Specification for Anchor Bolts, Steel, 36, 55, and 105-ksi Yield Strength

ASTM A563; Standard Specification for Carbon and Alloy Steel Nuts

ASTM F436; Standard Specification for Hardened Steel Washers Inch and Metric Dimensions

ASTM A1011; Standard Specification for Steel, Sheet and Strip, Hot-Rolled, Carbon, Structural, High-Strength Low-Alloy, High-Strength Low-Alloy with Improved Formability, and Ultra-High Strength

ASTM A572; Standard Specification for High-Strength Low-Alloy Columbium-Vanadium Structural Steel

ASTM A500; Standard Specification for Cold-Formed Welded and Seamless Carbon Steel Structural Tubing in Rounds and Shapes

4. Requirements

Aladdin arm assemblies shall conform to the details in Valmont drawing DB01175, Revision H, dated 1/21/2020.

Valmont shall inform SCL in writing of all updates to their drawing DB01175.

Aladdin arm assemblies shall be designed and fabricated to conform to the requirements of AASHTO standard Specifications for Structural Supports for Highway Signs, Luminaires, and Traffic Signals.

Aladdin arm assemblies shall conform to the requirements as shown in tables 4a and 4b, and figures 4a and 4b.

Finish shall be polyester powder-coated Sherwin Williams DGS-4003, Railroad Green color and AAMA 2604 compliant.

Table 4a. Aladdin Arm Assembly Components

Components	Material
Aladdin Finial ornament	Cast Aluminum
Finial Housing 6-5/8" dia. x 9"	Steel Tube
Finial Bottom plate and anchor	Cast Aluminum
Aladdin arm, Decorative Casting	Cast Aluminum
Door, for Aladdin arm, 6" x 6", "City of Seattle"	Cast Aluminum
Arm, 2" diam. Schedule 80 pipe (2.38" OD)	Aluminum
Base – Adaptive plate	Galvanized Steel
Threaded rods, fasteners	Stainless Steel

Figure 4a. Aladdin Arm Assembly Design and Components

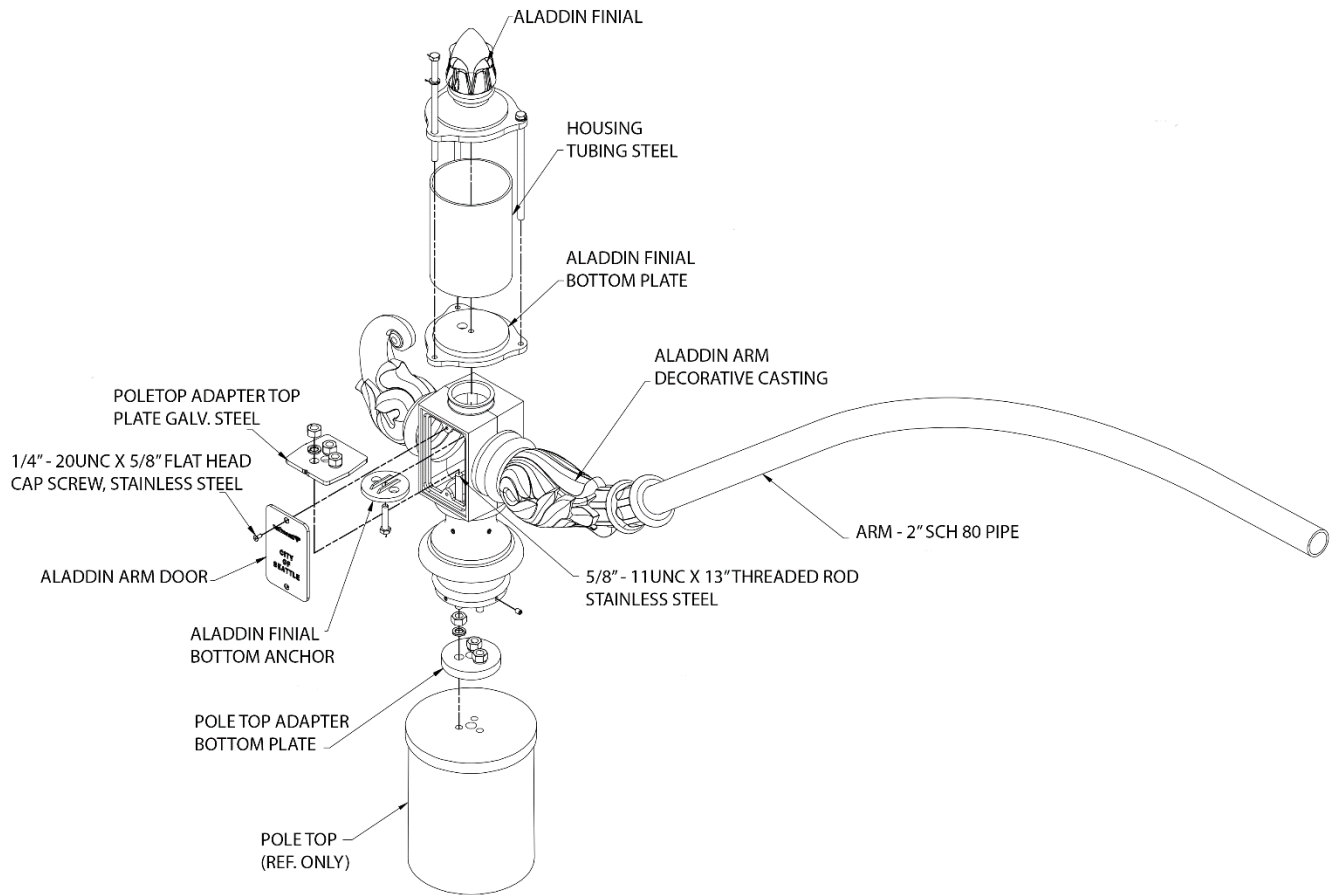

Figure 4b. Aladdin Arm Assembly Dimensions, Nominal

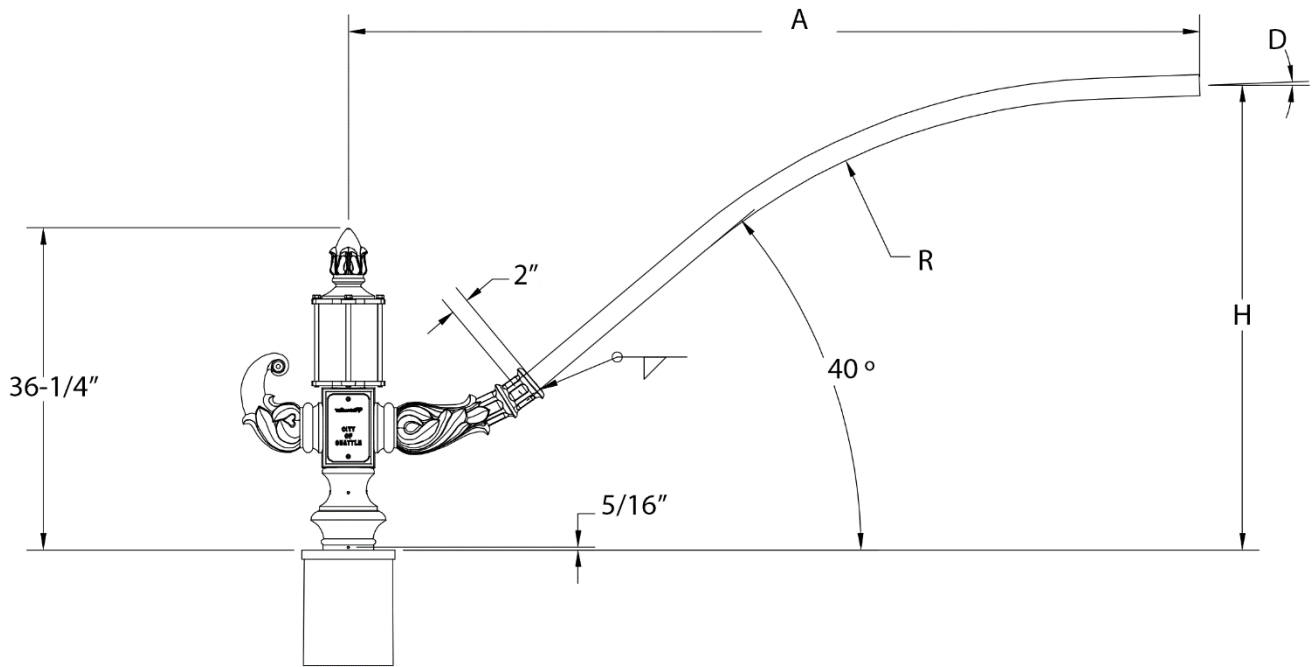

Table 4b. Aladdin Arm Assembly Dimensions, Nominal

Stock No.	Figure 4 Reference	012771	013536
Arm Length (in)	A	72	96
Arm Bend Radius (in)	R	37-1/2	73-1/2
Arm Rise (in)	H	44-1/2	52-1/4
Tenon Tilt (degrees)	D	5	2

5. Packaging

Aladdin arm assemblies shall be protected with a spiral wrapping of heavy waterproof paper for protection during shipping, outside storage and installation. A rip cord shall be provided for easy removal of wrapping.

Each arm assembly shall be legibly marked with the following information:

- Manufacturer identification
- Product description
- SCL stock number
- Quantity contained
- SCL purchase order number

6. Issuance

Stock unit: EA

7. Approved Manufacturers

Stock No.	Description	Valmont
012771	Aladdin Decorative Arm, 6-ft	J401113 – 6'
013536	Aladdin Decorative Arm, 8-ft	J388362 – 8'

8. References

AAMA 2604, Voluntary Specification, Performance Requirements and Test Procedures for High Performance Organic Coating on Aluminum Extrusions and Panels, 2005 (2020 latest revision)

SCL Material Standard 5756.22; Chief Seattle Ornamental Steel Streetlight Poles'

9. Sources

Borek, Tom, SCL Streetlight Engineer and subject matter expert for 5755.05

SCL Stock Catalog page 57-10, May 2, 2018

Valmont drawing, "SCL Decorative Street Light Pole 6' Span Aladdin Decorative Arm Seattle City Light Stock #012771", Drawing Number DB01175, Revision H, January 21, 2020

Valmont drawing, "SCL Decorative Street Light Pole 8' Span Aladdin Decorative Arm Seattle City Light Stock #013536", Drawing Number DB01175, Revision H, January 21, 2020

Wang, Quan; SCL Standards Engineer, originator, and subject matter expert for 5755.05.