

Pedestrian Luminaires, LED, Post-Top, Transitional



1. Scope

This standard covers the requirements for light-emitting diode (LED), post-top, transitional, pedestrian luminaires.

This standard applies to the following Seattle City Light (SCL) stock numbers:

Stock No.	Color	Description
015041	Gray	UrbanScape post-top LED luminaire, Type 2, 2700K
015042	Black	UrbanScape post-top LED luminaire, Type 2, 2700K
015044	Gray	UrbanScape post-top LED luminaire, Type 5, 2700K
015045	Black	UrbanScape post-top LED luminaire, Type 5, 2700K

2. Application

LED transitional pedestrian luminaires are:

- Post-top mounted on streetlight poles with a 4-in pole-top outer diameter.
- Equipped with built-in photocontrol housing with tool-less access for a standard, three-pin photocontrol.
- Controlled by 20-year design life streetlight photocontrols as specified in SCL 5731.17.

Type 2 fixtures produce focused lighting for areas where backlighting should be minimized. For example, type 2 should be used in residential areas where backlighting is a concern.

Type 5 fixtures should be used in locations where illumination is desired in all directions, for example, wide pathways or plazas.

Standard Coordinator
Laura Vanderpool

Standards Engineering Supervisor
Brett Hanson

Division Director
Bob Risch

3. Industry Standards

LED transitional pedestrian luminaires shall meet the applicable requirements of the following industry standards:

ANSI/NEMA/ANSLG C78.377; Specifications for the Chromaticity of Solid State Lighting (SSL) Products

ANSI C136.10; Locking-Type Photocontrol Devices and Mating Receptacles.\

ANSI C136.15; American National Standard for Roadway and Area Lighting Equipment – Internal Labeling of Luminaires

ANSI C136.22; American National Standard for Roadway and Area Lighting Equipment – Ingress Protection (Resistance to Dust, Solid Objects and Moisture) for Luminaire Enclosures

ANSI C136.31; American National Standard for Roadway Lighting Equipment – Luminaire Vibration

ANSI C136.37; American National Standard for Roadway and Area Lighting Equipment – Solid State Light Sources Used in Roadway and Area Lighting

ANSI C136.41; Dimming Control Between an External Locking Type Photocontrol and Ballast or Driver

ASTM B117-09; Standard Practice for Operating Salt Spray (Fog) Apparatus

ASTM D523-08; Standard Test Method for Specular Gloss

ASTM D1654-08; Standard Test Method for Evaluation of Painted or Coated Specimens Subjected to Corrosive Environments

ASTM D2247; Standard Practice for Testing Water Resistance of Coatings in 100% Relative Humidity

ASTM G154-06; Standard Practice for Operating Fluorescent Light Apparatus for UV Exposure of Nonmetallic Materials

Federal Trade Commission (FTC); Green Guides, 16 CFR Part 260; Guides for the Use of Environmental Marketing

IEC 60529; Degrees of protection provided by enclosures (IP Code), consolidated edition

IEEE C62.41.2; IEEE Recommended Practice on Characterization of Surges in Low-Voltage (1000 V and less) AC Power Circuits

IES LM-79-08; Approved Method: Electrical and Photometric Measurements of Solid-State Lighting Products

IES LM-80-08; Approved Method: Measuring Lumen Maintenance of LED Lighting Sources

IESNA TM-15-11 (revised); Luminaire Classification System for Outdoor Luminaires

RoHS (European Union Directive 2002/95/EC for Restriction of Hazardous Substances)

Title 47 of the Code of Federal Regulations (CFR), Part 15; Radio Frequency Devices

UL 1598; Luminaires; UL

4. Requirements

4.1 Luminaire Performance

Correlated color temperature (CCT), nominal, °K, per ANSI/NEMA/ANSI C78.377	2700 ± 200
Color rendering index (CRI), minimum	70
L70 Lumen depreciation of LED light sources per IES LM-80, hours, minimum	100,000
Light distribution, IES	Type 2 or Type 5
Luminaire efficacy, lumens/watt, minimum, per IES LM-79, Section 11.0	112
Off-state power consumption, W, maximum	0.5
Backlight, Uplight, and Glare (BUG) rating per IESNA TM-15, Addendum A	B3, U0, G1
Vibration withstand, minimum, per ANSI C136.31	Level 2 - 3G (bridge/overpass applications)

4.2 Power Supply/Driver

Input voltage, functional range, 60 Hz, Vac	120 to 277
Operating temperature, range	
°C	-40 to +55
°F	-40 to +130
Power factor, minimum	90
Dimming signal, control range, Vdc	0 to 10

4.3 Construction

4.3.1. General

Luminaires shall be designed and constructed to meet the requirements of ANSI C136.37.

Luminaire features conforming to ANSI C136.37 shall include but not be limited to the following: mounting provisions, latching and hinging, terminal blocks, dimming, ingress protection, wiring and grounding, and photocontrol receptacle.

Luminaires shall be compliant with RoHS (European Union Directive 2002/95/ED for Restriction of Hazardous Substances). Luminaire shall have less than the maximum concentration values of the following RoHS-restricted substances:

- Mercury (Hg)
- Cadmium (Cd)
- Chromium VI (Cr +6)
- Polybrominated biphenyl (PBB)
- Polybrominated biphenyl ether (PBDE)
- Lead (Pb)

4.3.2. Fixture Housing

Luminaire weight, lb, maximum	33
Effective projected area (EPA), ft ² , maximum	1.7
External housing, ingress protection per IEC 60529	IP65
Optical chamber, ingress protection per IEC 60529	IP66

Luminaire housing shall be cast aluminum and allow for tool-less entry.

All tool-less fasteners, latches, and knobs shall be stainless steel.

Photocontrol receptacle shall be located at the base of the luminaire and allow for tool-less entry.

Photocontrol mounting shall accommodate all City Light-approved photocontrols listed in material standard 5731.17.

Luminaire cooling system shall consist of a passive heat sink without fans, pumps, or liquids.

All aesthetic exterior fasteners shall be zinc-plated, ceramic coated, and corrosion resistant; painted the same color as the luminaire housing or other approved protective coating, e.g. ceramic primer-seal basecoat. Internal fasteners shall be stainless steel.

All polycarbonate components shall be UV stabilized.

4.3.3. Electrical

Power supply/driver shall be UL Recognized for dry and damp locations.

All other electrical components shall be UL Listed or UL Recognized for wet locations.

Photocontrol receptacles shall be designed and constructed to accept a standard plug type, locking, three-pole, three-wire, streetlight photocontrol, and shall be located at the base of the fixture.

Photocontrol receptacles shall have seven positions as defined in ANSI C136.41, including three twist-lock power contacts and four dimming or lighting control contacts.

Rotational adjustment of the photocontrol shall be tool-less.

Luminaire circuitry shall include quick connectors to allow easy separation and removal of driver and power door.

A three-pole terminal block capable of accepting #14 to #6 AWG wire shall be mounted to the housing inside the electrical compartment.

Terminal block shall be capable of operation with a standard #2 flat blade screwdriver.

Luminaire shall meet the requirements of Title 47 of the Code of Federal Regulations (CFR), Part 15 – Radio Frequency Devices.

4.3.4. Mounting

Luminaire shall be designed for post-top mounting onto a pole with a top diameter of 4 inches.

Tenon mounting area opening shall be limited to 1/4-in over the range of tenon sizes and leveling adjustment to prevent entrance of wildlife as specified in ANSI C136.37.

4.3.5. Lens

Lens shall be lightly diffused and resistant to ultraviolet light deterioration.

Lens shall be smooth on the exterior to discourage unwanted growth.

4.3.6. Finish and Color

Finish on housing shall be a powder coating with a minimum thickness of 100 microns and shall meet the salt spray requirements of ASTM B117 and the humidity resistance requirements of ASTM D2247.

5. Detailed Requirements, Stock Nos. 014357 and 014358, Urbanscape

Physical and electrical details for specific luminaires are provided below.

System power consumption (W)	35
Weight (lb)	32
EPA (ft ²)	1.7
Tenon mounting requirements, outside diameter by length (in)	4"Ø by 4"
Dimensions, height by width (in)	34 7/8" by 17 3/4"

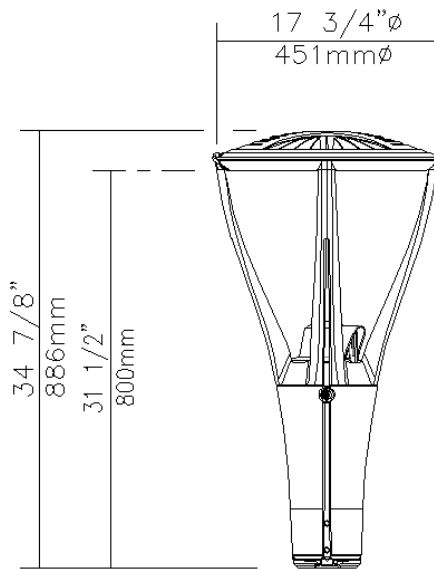

6. Testing

Manufacturers shall provide test data that establishes compliance with the requirements of this material standard upon request.

Certificate of RoHS (European Union Directive 2002/95/EC for Restriction of Hazardous Substance) compliance shall be provided upon request.

7. Design Changes

Manufacturer shall inform Seattle City Light in writing of all design changes that could affect the product's understood or published capabilities.

8. Marking

8.1 Internal Labeling

A readily visible label shall be permanently affixed to the inside surface of each luminaire housing.

Internal label shall meet the requirements of ANSI C136.22.

Internal label shall include, but not be limited to, the following information:

- Manufacturer name and catalog number
- Month and year of manufacture
- Line input voltage
- Frequency if other than 60 Hz
- Driver type, if applicable (may be on driver if readily visible)
- Photocontrol voltage if different from line input voltage
- Lamp type, wattage, and voltage, if applicable (may be on driver if readily visible)
- Plant location
- Input power consumption
- Driver output current
- Driver output adjustment
- IEC IP rating
- Correlated color temperature (CCT)
- IES light distribution type
- IESNA TM-15 BUG ratings
- Serial number

8.2 Barcode

A barcode label shall be provided as specified in the purchase order.

8.3 Component Identification

All UL Listed components shall be labeled or recognized as such.

9. Packaging

Luminaires shall be individually packaged to prevent damage during shipping, inside storage, and casual handling prior to installation.

Each package shall be legibly marked with:

- Manufacturer name
- Manufacturer catalog number
- Product description
- Date of manufacture (month and year)
- Seattle City Light stock number
- Seattle City Light purchase order number

Accessories shall be individually packaged to prevent damage during shipping, inside storage, and casual handling prior to installation.

Each package shall be legibly marked with:

- Product description
- Seattle City Light stock number

10. Issuance

Unit: EA

11. Approved Manufacturers

11.1 Stock No. 015041

Manufacturer: Philips Lumec
Catalog Number: **[MPTC-021]-35W-32LED-2.7K-G3-LE2-UNV-DMG-[FAWS-013]-HS-PH8-RCD7-GY3TX**

where:

[MPTC-021] = model, S56, tool-less latch, stainless steel
35W = wattage, 35 W
32LED = number of LEDs, 32
2.7K = color temperature, 2700K
G3 = LED board engine, Generation 3
LE2 = light distribution, type 2
UNV = voltage, 120-277 Vac
DMG = driver, dimming compatible 0–10 V
[FAWS-013] = Field Adjustable Wattage Selector
HS = house shield
PH8 = options, photoelectric cell receptacle, twist-lock
RCD7 = 7-pin receptacle, dimming
GY3TX = finish, textured gray

11.2 Stock No. 015042

Manufacturer: Philips Lumec
Catalog Number: **[MPTC-021]-35W-32LED-2.7K-G3-LE2-UNV-DMG-[FAWS-013]-HS-PH8-RCD7-BKTX**

where:

[MPTC-021] = model, S56, tool-less latch, stainless steel
35W = wattage, 35 W
32LED = number of LEDs, 32
2.7K = color temperature, 2700K
G3 = LED board engine, Generation 3
LE2 = light distribution, type 2
UNV = voltage, 120-277 Vac
DMG = driver, dimming compatible 0–10 V
[FAWS-013] = Field Adjustable Wattage Selector
HS = house shield
PH8 = options, photoelectric cell receptacle, twist-lock
RCD7 = 7-pin receptacle, dimming
BKTX = finish, textured black

11.3 Stock No. 015044

Manufacturer:	Philips Lumec
Catalog Number:	[MPTC-021]-35W-32LED-2.7K-G3-LE5-UNV-DMG-[FAWS-013]-PH8-RCD7-GY3TX
<i>where:</i>	
[MPTC-021] =	model, S56, tool-less latch, stainless steel
35W =	wattage, 35 W
32LED =	number of LEDs, 32
2.7K =	color temperature, 2700K
G3 =	LED board engine, Generation 3
LE5 =	light distribution, type 5
UNV =	voltage, 120-277 Vac
DMG =	driver, dimming compatible 0–10 V
[FAWS-013] =	Field Adjustable Wattage Selector
PH8 =	options, photoelectric cell receptacle, twist-lock
RCD7 =	7-pin receptacle, dimming
GY3TX =	finish, textured gray

11.4 Stock No. 015045

Manufacturer:	Philips Lumec
Catalog Number:	[MPTC-021]-35W-32LED-2.7K-G3-LE5-UNV-DMG-[FAWS-013]-PH8-RCD7-BKTX
<i>where:</i>	
[MPTC-021] =	model, S56, tool-less latch, stainless steel
35W =	wattage, 35 W
32LED =	number of LEDs, 32
2.7K =	color temperature, 2700K
G3 =	LED board engine, Generation 3
LE5 =	light distribution, type 5
UNV =	voltage, 120-277 Vac
DMG =	driver, dimming compatible 0–10 V
[FAWS-013] =	Field Adjustable Wattage Selector
PH8 =	options, photoelectric cell receptacle, twist-lock
RCD7 =	7-pin receptacle, dimming
BKTX =	finish, textured black

12. References

SCL Material Standard 5693.10; “Streetlight Photocontrols, 20-Year Design Life”

13. Sources

Borek, Tom; SCL Streetlight Engineering Supervisor and subject matter expert for 5723.15

Chao, Yaochiem; SCL Standards Engineer and originator of 5723.15

Philips Lumec; drawing no. SPEC20240123_123049_80352_404.DOC, revision February 8, 2024

Philips Lumec; drawing no. SPEC20240123_123027_80352_405.DOC, revision February 8, 2024

www.signify.com/en-us