

Brackets, Ground Wire



1. Scope

This standard covers the requirements for ground wire brackets.
This standard applies to Seattle City Light (SCL) Stock No. 565005.

2. Application

Ground wire brackets are used for supporting transmission line ground wires on wood poles.
Each ground wire bracket is provided with a chain link.

3. Requirements

Ground wire brackets shall be:

- Manufactured from ductile iron
- Have an ultimate strength rating of 5000 lb
- Manufactured with the dimensions shown in Figure 3

Ground wire brackets shall be provided with a chain link.

Handwritten signature of Curtis Lu in black ink.

Handwritten signature of John Shipek in black ink.

Handwritten signature of Andrew Strong in black ink.

Figure 3. Bracket Dimensions

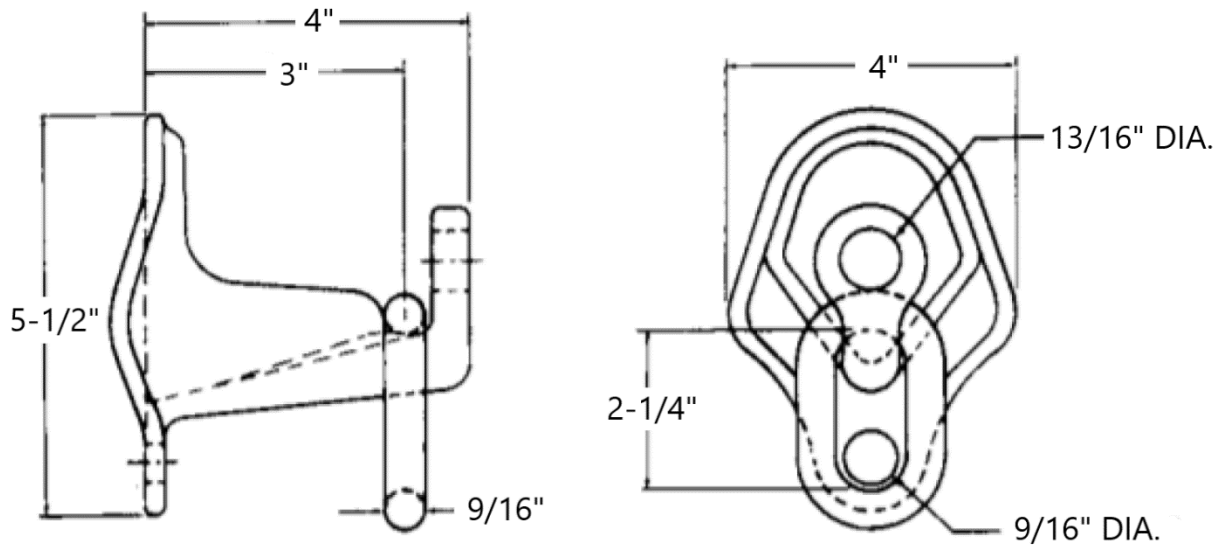

4. Packaging

Ground wire brackets shall be packaged to prevent damage during shipping, handling, and inside storage.

Ground wire brackets shall be packaged together with their chain link.

Individual packages shall be legibly marked with:

- Manufacturer name
- Manufacturer part number
- Product description
- SCL stock number

Shipping containers shall be legibly marked with:

- SCL purchase order number

5. Issuance

Stock Unit: EA

6. Approved Manufacturers

Manufacturer	Catalog No.
Hubbell Power Systems	GWB1S

7. Sources

SCL Stock Catalog page 56-5; June 20, 2017

Lu, Curtis; SCL Standards Engineer and originator of 5632.14