

Switchgear, 27 kV, Three-Phase, Dead-Front, Padmount



Table of Contents

1. Scope	2
2. Application	2
3. Industry Standards	2
4. Construction	2
5. Switchgear Ratings	5
6. Grounding	6
7. High-Voltage Bus	6
8. Nameplate	6
9. Documentation	7
10. Packaging	7
11. Shipping	7
12. Issuance	7
13. Detailed Requirements	8
14. Sources	12

Standard Coordinator
Muneer Shetab

Standards Engineering Supervisor
John Shipek

Division Director
Tamara Jenkins

Muneer Shetab *John Shipek*

Tamara Jenkins

1. Scope

This standard covers the requirements for 27 kV, three-phase, dead-front switchgear.

This standard applies to the following Seattle City Light (SCL) stock numbers:

Stock No.	Type	Fuse Ways	Switch Ways
014805	PME/PSE-9	2	2
014806	PME/PSE-10	0	4
014807	PME/PSE-11	1	3
014808	PME/PSE-12	3	1

2. Application

This switchgear is intended for use on 27 kV, three-phase, 60 Hz, grounded neutral underground distribution systems where the available fault current is less than 25 kA rms symmetrical.

Dead-front switchgear is much safer to operate than live-front switchgear and should be an engineer's first choice for new installations.

PME type switchgear is manufactured by the S&C Electric Company. PSE type switchgear is manufactured by Federal Pacific Electric. PME and PSE type switchgear are functionally equivalent and interchangeable.

3. Industry Standards

Switchgear shall meet the applicable requirements of the latest revision of the following industry standards:

IEEE C37.74; IEEE Standard Requirements for Subsurface, Vault, and Pad-mounted Load-Interrupter Switchgear and Fused Load-Interrupter Switchgear for Alternating Current Systems Up to 38 kV

IEEE C37.60; High-voltage Switchgear and Control Gear

IEEE C57.12.28; IEEE Standard for Pad-Mounted Equipment – Enclosure Integrity

IEEE 386; IEEE Standard for Separable Insulated Connector Systems for Power Distribution Systems Above 600 V

IEEE 1584; Guide for Performing Arc-Flash Hazard Calculations

NEMA L1-1; Industrial Laminating Thermosetting Products

4. Construction

4.1 General

The switchgear assembly shall be integrally designed and produced by the manufacturer of the individual switch components. The manufacturer shall be solely responsible for the performance of the individual switch components as well as the assembly.

All switchgear components shall be factory assembled and tested.

4.2 Design Changes

The manufacturer shall inform SCL in writing of all design changes that could affect the understood or published capabilities of the switchgear.

4.3 Quality

Switchgear design and construction shall be of high quality and provide safe and reliable operation with minimal maintenance over the life of the product.

4.4 Enclosure

The switchgear cabinet shall be of unitized construction (not structural frame and bolted sheet) to maximize strength, minimize weight, and inhibit internal corrosion.

All live parts shall be completely encased in an inner grounded steel compartment.

4.4.1. Material

The cabinet and doors shall be fabricated from 11-gauge steel sheet or better.

All structural joints and butt joints shall be welded.

External seams shall be ground flush and smooth.

4.4.2. Finish

The color shall be Munsell No. 7GY3.29/1.5, dark green or approved equivalent.

4.4.3. Roof

The entire underside of the roof shall be coated with a "no-drip" compound to reduce condensation.

4.4.4. Base Spacer

The switchgear enclosure shall have a 6-inch, carbon steel base spacer.

The base spacer shall be factory assembled and attached to the enclosure. Shipping the hardware loose is not acceptable.

4.4.5. Base Adapter

The switchgear shall also have a 6-inch, stainless steel base adapter.

The base adapter shall be designed to allow the switchgear to be installed on top of smaller, live-front, S&C type PMH switchgear foundations.

The bottom of the base adapter shall consist of continuous, 90-degree flanges, turned inward for bolting to the concrete pad.

The base adapter shall be factory assembled and attached to the enclosure. Shipping the hardware loose is not acceptable.

Coupled with the 6-inch base spacer, the combined 12-inch overall base spacing increases the elevation of live parts in the switchgear above the mounting pad.

4.4.6. Doors

Door edge flanges shall overlap with door opening flanges and shall be formed to create a mechanical maze that shall guard against water entry or discourage tampering or insertion of foreign objects.

Each switch compartment door shall have mounting provisions to accommodate a 3-phase fault indicator as well as a viewing window in the door.

One active and one passive door shall be provided. In consideration of controlled access and tamper resistance, each active door shall be equipped with a positive-action three-point auto-latch mechanism and padlock hasp.

Each active door shall be provided with a hinged stainless-steel cover over the operating bolt. The cover shall be padlockable and shall incorporate a hood to protect the padlock shackle from tampering and access to the operating bolt. Each handle shall be provided with a recessed penta-head (hex optional) bolt for additional security.

Doors providing access to fuses shall have provisions to store spare expulsion type fuse units or refills.

Each door shall be provided with a stainless-steel door holder. These holders shall be hidden from view when the door is closed.

4.4.7. Lifting Tabs

Lifting tabs shall be removable.

Sockets for the lifting-tab bolts shall be blind-tapped.

A protective material shall be placed between the lifting tabs and the enclosure to prevent the tabs from scratching the enclosure finish. This material shall be non-hygroscopic to prevent moisture from being absorbed.

4.4.8. Barrier Assembly

Insulating barriers shall be provided in each switch and fuse compartment as required to achieve necessary insulation levels.

This barrier system shall be constructed of fiberglass reinforced polyester (NEMA L1-1 rated GPO-3).

4.5 Switch Compartments

4.5.1. Switch Terminals

Switch terminals shall be equipped with 600 A-rated bushings with removable silver-plated copper threaded studs.

Switch termination compartment depth shall be sized to accommodate 600A elbows with 200 A loadbreak reducing tap plugs and grounding elbows with the doors closed.

Bushings and bushing wells shall be mounted so that the semiconducting coating of these devices is solidly grounded to the enclosure.

4.5.2. Interrupter Switches

Interrupter switches shall have a three-time duty cycle fault-closing rating equal to or exceeding the short-circuit rating of the pad-mounted switchgear. These ratings define the ability to close the interrupter switch three times against a three-phase fault with asymmetrical current in at least one phase equal to the rated value, with the switch remaining operable and able to carry the interrupt-rated current.

Interrupter switches shall be dry-type, in-air, three-phase, gang-operated through an operating handle external to the enclosure.

Interrupter switches shall be provided with contact blades and interrupters for circuit closing, including fault-closing, continuous current carrying and circuit interrupting.

Interrupter switches shall have a readily visible open gap when in the open position.

An open/close label shall also be provided to give a visual indication of the switch position.

Unbreakable, mar-resistant viewing windows will be provided in the switch termination compartments to allow visual verification of the switch position.

Interrupter switches shall utilize a quick-make, quick-break mechanism installed by the switch manufacturer.

Interrupter switches shall be designed to prevent formation of external arc or flames when it is operated.

4.5.3. Operating Handle

Each switch compartment switch shall be equipped with an externally mounted operating handle.

The handle shall be secured to the inside of the operating hub pocked by a corrosion-resistant chain or wire cable. The handle shall be capable to be stored behind the switch operating hub access door.

The operating hub shall be provided with labels that indicate the position of the switch.

The switch handle shall be equipped with provisions to padlock it in the open or closed position.

4.6 Fuse Compartments

4.6.1. Fuse Terminals

Fuse terminals shall be equipped with 200 A-rated bushing wells that have interfaces designed in accordance with IEEE 386.

4.6.2. Access

Fuse access panels shall have a mechanical interlock that guards against gaining access to the fuse before operating the loadbreak, separable, insulated connector at the fuse terminal.

The fuse shall be accessible only when de-energized and isolated.

4.6.3. Viewing Windows

Fuse compartments shall be equipped with viewing windows that allow easy identification of activated fuse indicators.

4.6.4. Power Fuse Type

Switchgear with fuse termination compartments shall be designed to accept Cooper Power Systems Combined Technologies (CT) X-Limiter full-range current-limiting fuses.

The manufacturer shall furnish the appropriate fuse holders to accommodate the X-Limiter fuse. The fuse holders shall come pre-mounted in the switchgear fuse compartment.

The switchgear shall be designed to accept clip-style or hinge-mounted X-Limiter fuses listed in Table 4.6.4.

Table 4.6.4 Eaton/Cooper Fuse Catalog Numbers

Current Rating (A)	For S&C Electric Company Switchgear (Clip-Style Fuse)	For Federal Pacific Switchgear (Hinge-Mount Fuse)
25	15F025EHC2AN	155F025-I
40	15F040EHC2AN	155F040-I
65	15F065EHC2AN	155F065-I

5. Switchgear Ratings

The manufacturer shall furnish certified tests establishing the electrical ratings of the switchgear including ratings of the basic switches and fuse components upon request.

Each fused tap, fuse, and fuse assembly shall be capable of withstanding full line-to-line voltage of 27 kV across each fuse unit after operation.

The switchgear assembly shall have electrical ratings as shown in Table 5.

Table 5. Switchgear Assembly Ratings

Rated frequency (Hz)	60
Maximum voltage (kV)	27
Number of phases	3
Basic insulation level (BIL) (kV)	125
Main bus continuous current (A)	600
Short circuit	
Peak withstand current, amperes, peak	32,500
One-second short-time current withstand current (rms symmetrical)	12,500
MVA, three-phase symmetrical at rated nominal voltage	540
Three-pole interrupter switches	
Continuous current (A)	600
Load-dropping current (A)	600
Three-time duty-cycle fault-closing current, peak (A)	32,500
Fuse bays	
Continuous current (fuse) (A)	200
Load dropping current (fuse) (A)	200

6. Grounding

A ground connection pad shall be provided in each termination compartment of the pad-mounted gear.

The ground connection pad shall be constructed of 1/4-inch-thick stainless steel and have a NEMA 2-hole pattern for ground connections.

The pad shall be welded to the enclosure and shall have a short-circuit rating equal to that of the integrated assembly.

A full-width copper grounding rod shall be provided in each cable-termination compartment.

7. High Voltage Bus

The bus and interconnections shall be constructed of aluminum bar of 56% IAC conductivity.

8. Nameplate

Each switch shall be provided with a nameplate that meets the requirements of IEEE C27.74.

The exterior nameplate can also be made from aluminum and attached with adhesive.

The exterior and nameplate shall include the following information:

- Manufacturer catalog number
- Model number
- Serial number
- Date of manufacture

The interior label shall contain all the information shown on the exterior nameplate as well as the following:

- Switchgear ratings specified in Section 5
 - Electrical one-line diagram
-

9. Documentation

One instruction book shall be securely attached to each switch in an ultraviolet light-resistant envelope.

Provision shall be made for SCL to obtain PDF files of all relevant, switch-specific documentation, such as:

- Installation instructions
 - Operation and maintenance instructions
 - Outline drawings
 - Wiring and schematic drawings
-

10. Packaging

Each switch shall be packaged and delivered on its own pallet.

The pallet shall be compatible with either a pallet jack or forklift.

The two openings for the pallet jack or forklift shall have a minimum height of 4 inches and width of 21 inches.

The crate and pallet, including slats, blocking, and wedges, shall be unpainted wood.

The outside of each crate shall be permanently and clearly marked with the following:

- Manufacturer name or symbol
 - Seattle City Light purchase order number
 - Seattle City Light stock number
 - Manufacturer equipment serial number
-

11. Shipping

Switches may be delivered on enclosed, covered, or flatbed trucks. If switches are delivered on a flatbed truck, switches shall be side-loaded.

Washington State law requires a 10-in minimum sideboard when driving a forklift or pallet jack onto the bed of a truck or trailer; therefore, most flatbed trucks or trailers must be side-loaded to ease off-loading.

12. Issuance

Stock Unit: EA

13. Approved Manufacturers

13.1 PME/PSE-9 Switchgear, Stock No. 014805

Manufacturer:	S&C Electric Company Catalog No.
Catalog Number:	65553R1-E3-F2-K7-K10
<i>where:</i>	
65 =	manual
5 =	Fault-Fiter fuse mounting
5 =	PME-9 switchgear model
3 =	25 kV voltage class (27 kV maximum)
R1 =	revision 1
E3 =	fuse storage, compartments 1 and 2
F2 =	mounting provisions for fault indicators with viewing window in door
K7 =	6-inch carbon steel base spacer
K10 =	6-inch stainless steel base adapter for PMH switchgear

Manufacturer:	Federal Pacific Electric Catalog No.
Catalog Number:	PSE-9-5-4-2-2-2-7-A2-A2S99-E3-HR-LBI-T7
<i>where:</i>	
PSE-9 =	PSE-9 switchgear model
5 =	25 kV voltage class (27 kV maximum)
4 =	# of compartments
2 =	# of switch compartments
2 =	# of fuse compartments
7 =	CT X-Limiter fuse type
A2 =	6-inch mild steel base spacer
A2S99 =	6-inch stainless steel base adapter
E3 =	fuse storage hooks, compartments 3 and 4
HR =	hinged roof
LBI =	loadbreak inserts installed
T7 =	mounting provisions for three-phase fault indicators, with window in door

Figure 13.1. PME/PSE-9 Switchgear Connection Diagram

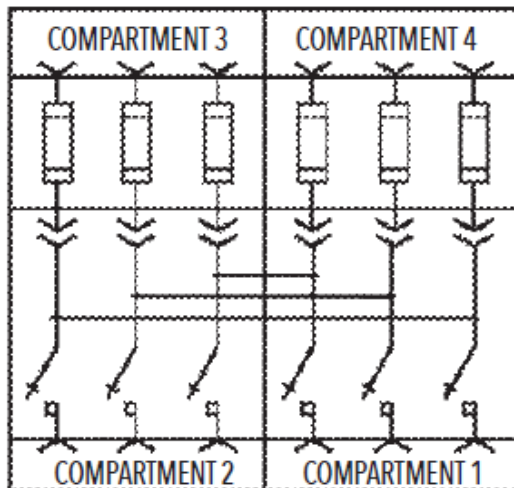

13.2 PME/PSE-10 Switchgear, Stock No. 014806

Manufacturer:	S&C Electric Company Catalog No.
Catalog Number:	65543R1-F2-K7-K10
<i>where:</i>	
65 =	manual PME switchgear
5 =	Fault-Fiter fuse mounting
4 =	PME-10 switchgear model
3 =	25 kV voltage class (27 kV maximum)
R1 =	revision 1
F2 =	mounting provisions for fault indicators with viewing window in door
K7 =	6-inch carbon steel base spacer
K10 =	6-inch stainless steel base adapter for PMH switchgear

Manufacturer:	Federal Pacific Electric Catalog No.
Catalog Number:	PSE-10-5-4-4-00-A2-A2S99-HR-T7
<i>where:</i>	
PSE-10 =	PSE-10 switchgear model
5 =	25 kV voltage class (27 kV maximum)
4 =	# of compartments
4 =	# of switch compartments
00 =	no fuse or type
A2 =	6-inch mild steel base spacer
A2S99 =	6-inch stainless steel base adapter
HR =	hinged roof
T7 =	mounting provisions for three-phase fault indicators, with window in door

Figure 13.2. PME/PSE-10 Switchgear Connection Diagram

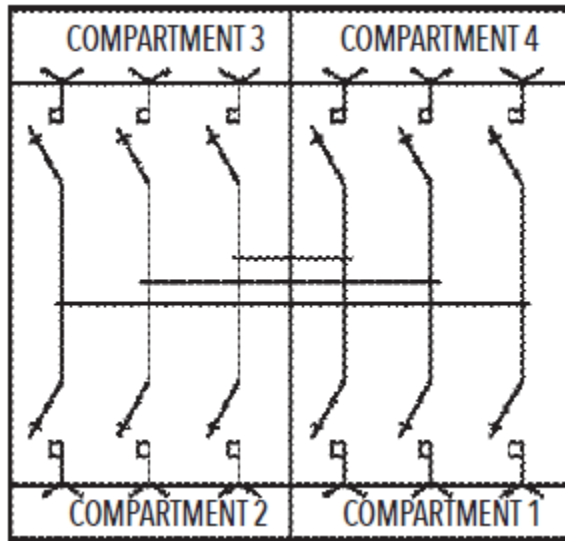

13.3 PME/PSE-11 Switchgear, Stock No. 014807

Manufacturer: S&C Electric Company Catalog No.

Catalog Number: 65563R1-E3-F2-K7-K10

where:

- 65 = Manual PME switchgear
- 5 = Fault-Fiter fuse mounting
- 6 = PME-11 switchgear model
- 3 = 25 kV voltage class (27 kV maximum)
- R1 = revision 1
- E3 = fuse storage, compartments 1 and 2
- F2 = mounting provisions for fault indicators with viewing window in door
- K7 = 6-inch carbon steel base spacer
- K10 = 6-inch stainless steel base adapter for PMH switchgear

Manufacturer: Federal Pacific Electric Catalog No.

Catalog Number: PSE-11-5-4-3-1-7-A2-A2S99-E6-HR-LBI-T7

where:

- PSE-11 = PSE-11 switchgear model
- 5 = 25 kV voltage class (27 kV maximum)
- 4 = # of compartments
- 3 = # of switchgear compartments
- 1 = # of fuse compartments
- 7 = CT X-Limiter fuse type
- A2 = 6-inch mild steel base spacer
- A2S99 = 6-inch stainless steel base adapter
- E6 = fuse storage hooks, compartment 3
- HR = hinged roof
- LBI = load break inserts installed
- T7 = mounting provisions for three-phase fault indicators, with window in door

Figure 13.3. PME/PSE-11 Switchgear Connection Diagram

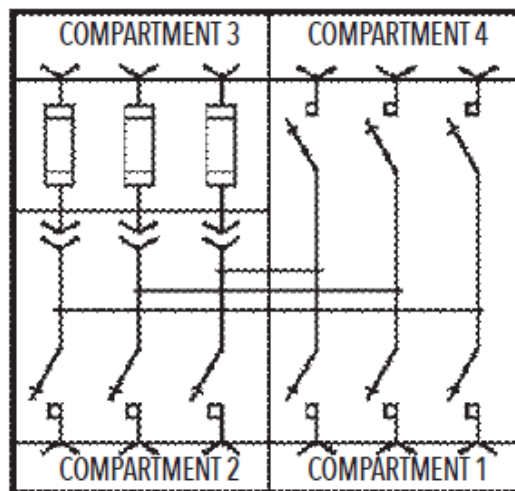

13.4 PME/PSE-12 Switchgear, Stock No. 014808

Manufacturer: S&C Electric Company Catalog No.

Catalog Number: **65573R1-E2-F2-K7-K10**

where:

- 65 = manual PME switchgear
- 5 = Fault-Fiter fuse mounting
- 7 = PME-12 switchgear model
- 3 = 25 kV voltage class (27 kV maximum)
- R1 = revision 1
- E2 = fuse storage, compartment 2
- F2 = mounting provisions for fault indicators with viewing window in door
- K7 = 6-inch carbon steel base spacer
- K10 = 6-inch stainless steel base adapter for PMH switchgear

Manufacturer: Federal Pacific Electric Catalog No.

Catalog Number: **PSE-12-5-4-1-3-7-A2-A2S99-E3-E4-HR-LBI-T7**

where:

- PSE-12 = PSE-12 switchgear model
- 5 = 25 kV voltage class 27 kV maximum)
- 4 = # of compartments
- 1 = # of switch compartments
- 3 = # of fuse compartments
- 7 = CT X-Limiter fuse type
- A2 = 6-inch mild steel base spacer
- A2S99 = 6-inch stainless steel base adapter
- E3 = fuse storage hooks, compartments 3 and 4
- E4 = Fuse storage hooks, compartment 1
- HR = hinged roof
- LBI = load break inserts installed
- T7 = mounting provisions for three-phase fault indicators, with window in door

Figure 13.4. PME/PSE-12 Switchgear Connection Diagram

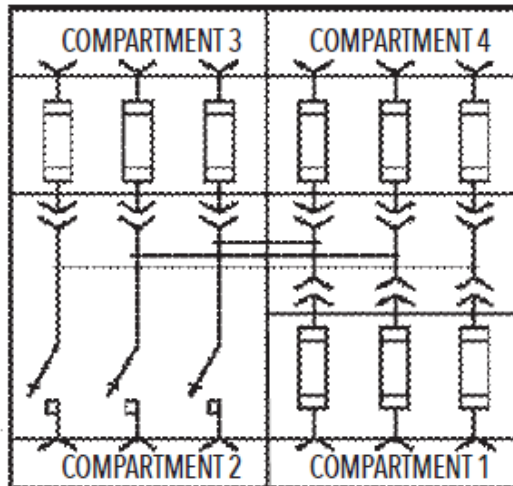

14. Sources

S&C Specification Bulletin 665-31, S&C Manual PME Pad-Mounted Gear, Outdoor Distribution (14.4 kV and 25 kV), December 11, 2017

S&C Descriptive Bulletin 665-30, Manual PME Pad-Mounted Gear, Air-Insulated, Dead-Front, Outdoor Distribution at 14.4 kV and 25 kV, October 5, 2020

S&C Information Sheet 665-451, Detailed Functional Specification Guide, S&C Manual PME Pad-Mounted Gear, Outdoor Distribution (14.4 kV and 25 kV), November 9, 2009

Federal Pacific Electric Product Bulletin PB-2A-215, Type PSE Manual Dead-Front Pad-Mounted Switchgear, June 2021

Federal Pacific Electric Switchgear Product Catalog, Type PSE Manual Dead-Front Pad-Mounted Switchgear

Shetab; Muneer; SCL Standards Engineer, originator, and subject matter expert for 4507.80