

115 kV Tangent Pole Top Assemblies

1. Scope

This standard provides the information necessary to construct the pole top assemblies for 115 kV single-circuit tangent poles supporting 795 and 954 kcmil ACSR conductors on the 115 kV transmission system.

Criteria for pole top assemblies covered under this standard include the following:

Grade of construction	B
Design criteria	NESC Medium, No Uplift
Pole class	H1 or stronger
Soil condition	Average
Allowable line angle	0°-5°

For line angles greater than the allowable line angles described above, refer to SCL 1621.20.

Composite, steel, laminated, and other non-wood poles are outside the scope of this standard.

2. Application

115 kV tangent pole tops can be constructed in horizontal or vertical configurations.

This standard provides direction to Seattle City Light (SCL) engineers, crews, and contractors for the installation of single-circuit, tangent pole top assemblies on 115 kV transmission poles with 745 kcmil ACSR and 954 kcmil ACSR conductors.

3. Requirements

This standard addresses two construction-framing configurations: without static wire and with static wire.

All line angles shall be constructed on the bi-sector.

Pole top assemblies shall be constructed as shown in Table 3.

Table 3. 115 kV Tangent Pole Top Assemblies

Conductor Size	Framing Type	Figure(s)
795 or 954 kcmil ACSR	Horizontal	3a, 3b
795 or 954 kcmil ACSR	Horizontal, with static wire	3c, 3d, 3i
795 or 954 kcmil ACSR	Vertical	3e, 3f
795 or 954 kcmil ACSR	Vertical, with static wire	3g, 3h, 3i

Standard Coordinator
Curtis Lu



Standards Engineering Supervisor
Brett Hanson



Division Director
Bob Risch



The insulator shall not have any amount of conductor uplift (negative weight-span) condition. Any uplift may result in failure of the insulator clamp.

For grounding of static wire, see SCL 0462.10.

Figure 3a. Allowable Line Angle Range 0°-5° for 795 kcmil ACSR and 954 kcmil ACSR Horizontal Tangent Pole, Without Static Wire, Top View

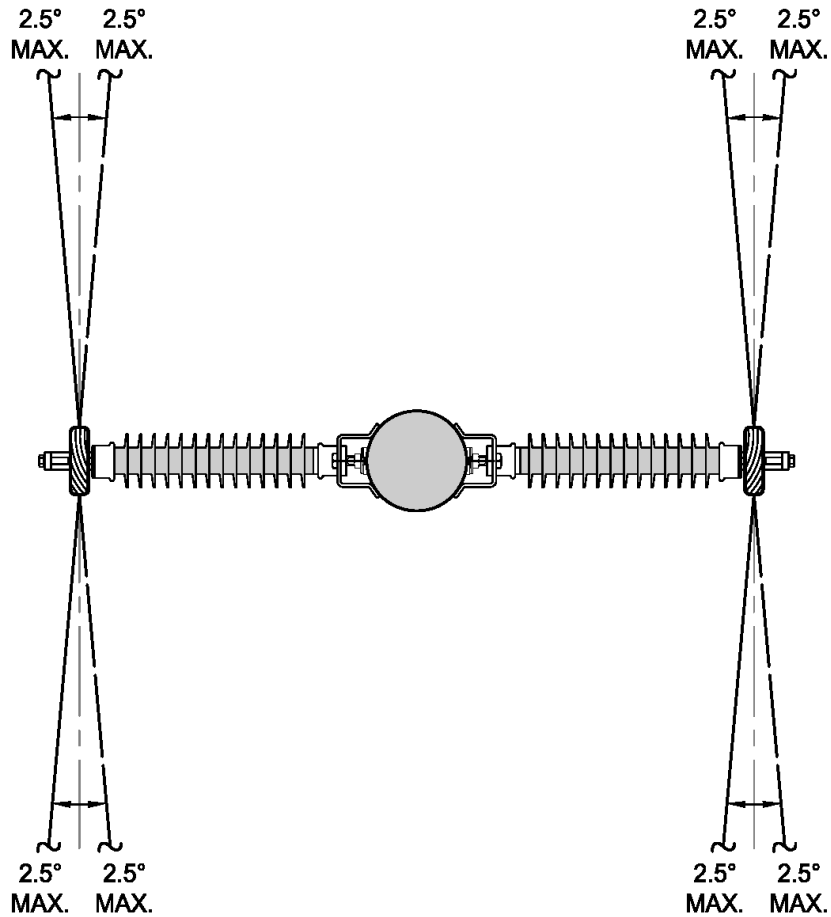
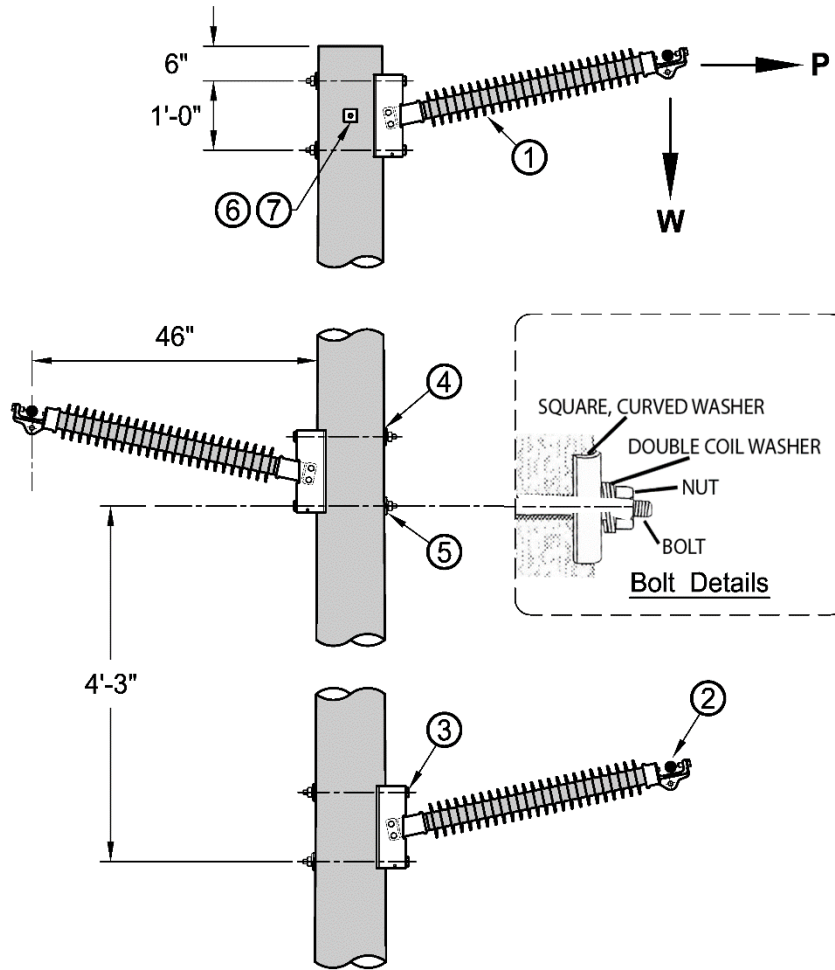

Figure 3b. 115 kV Horizontal Tangent Pole, Without Static Wire



Notes:

1. Maximum vertical weight (W) not to exceed 1515 lb.
2. Maximum horizontal pull (P) not to exceed 2000 lb.

**Figure 3c. Allowable Line Angle Range 0°-5° for 795 and 954 kcmil ACSR
Horizontal Tangent Pole, with Static Wire, Top View**

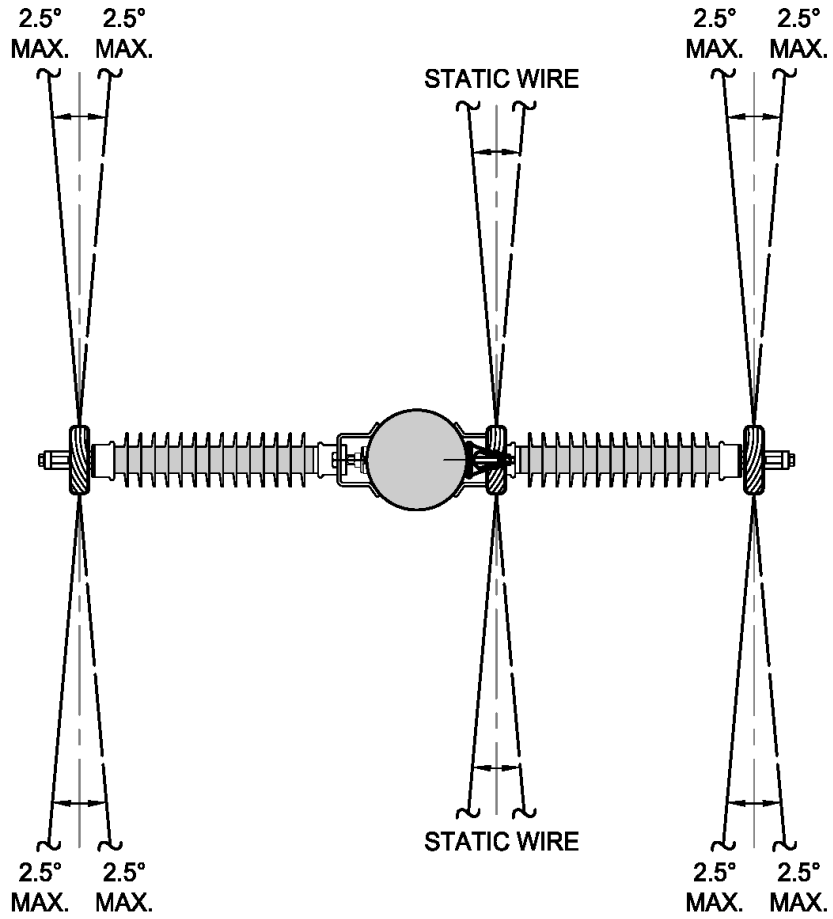
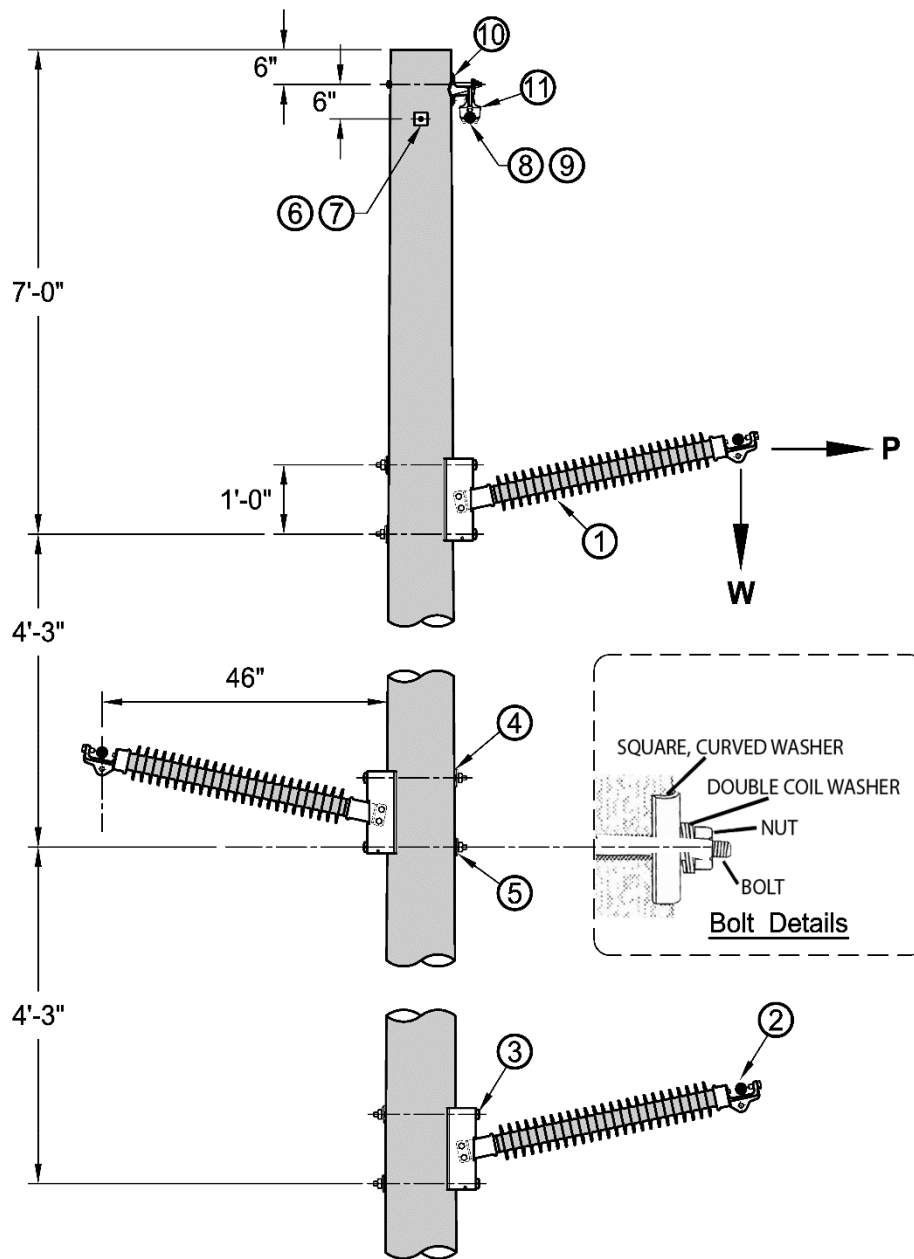

Figure 3d. 115 kV Horizontal Tangent Pole with Static Wire



- Notes:**
1. Maximum vertical weight (W) not to exceed 1515 lb.
 2. Maximum horizontal pull (P) not to exceed 2000 lb.

Figure 3e. Allowable Line Angle, Range 0°-5° for 795 kcmil and 954 kcmil ACSR Vertical Tangent Pole, Without Static Wire, Top View

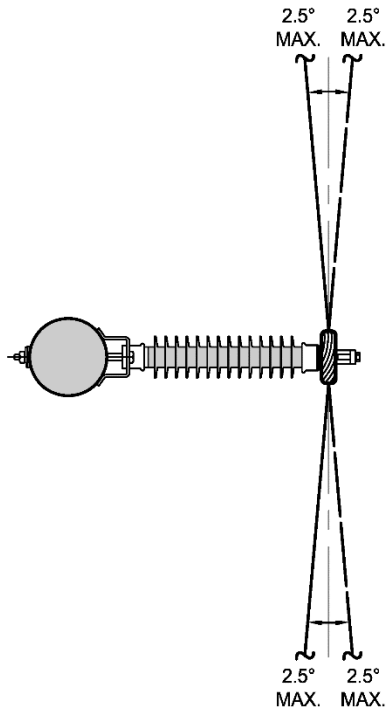
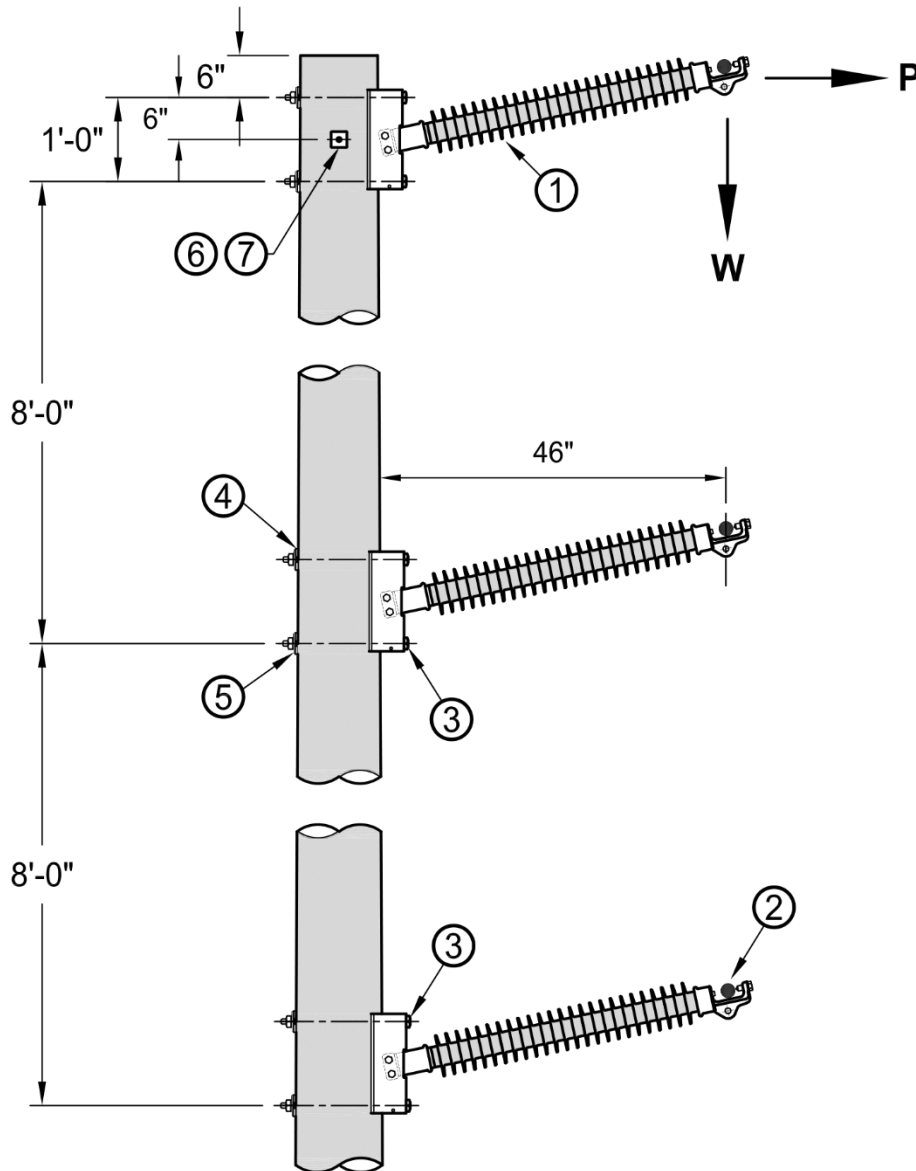

Figure 3f. 115 kV Vertical Tangent Pole, Top Assembly, Without Static Wire



Notes:

1. Maximum vertical weight (W) not to exceed 1515 lb.
2. Maximum horizontal pull (P) not to exceed 2000 lb.

**Figure 3g. Allowable Line Angle, Range 0°-5° for 795 kcmil and 954 kcmil ACSR
Vertical Tangent Pole with Static Wire, Top View**

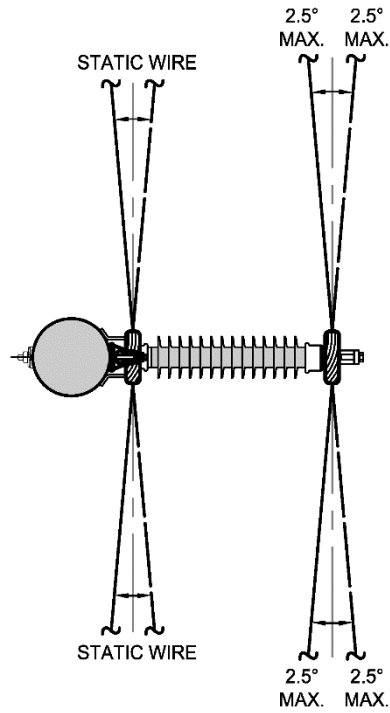
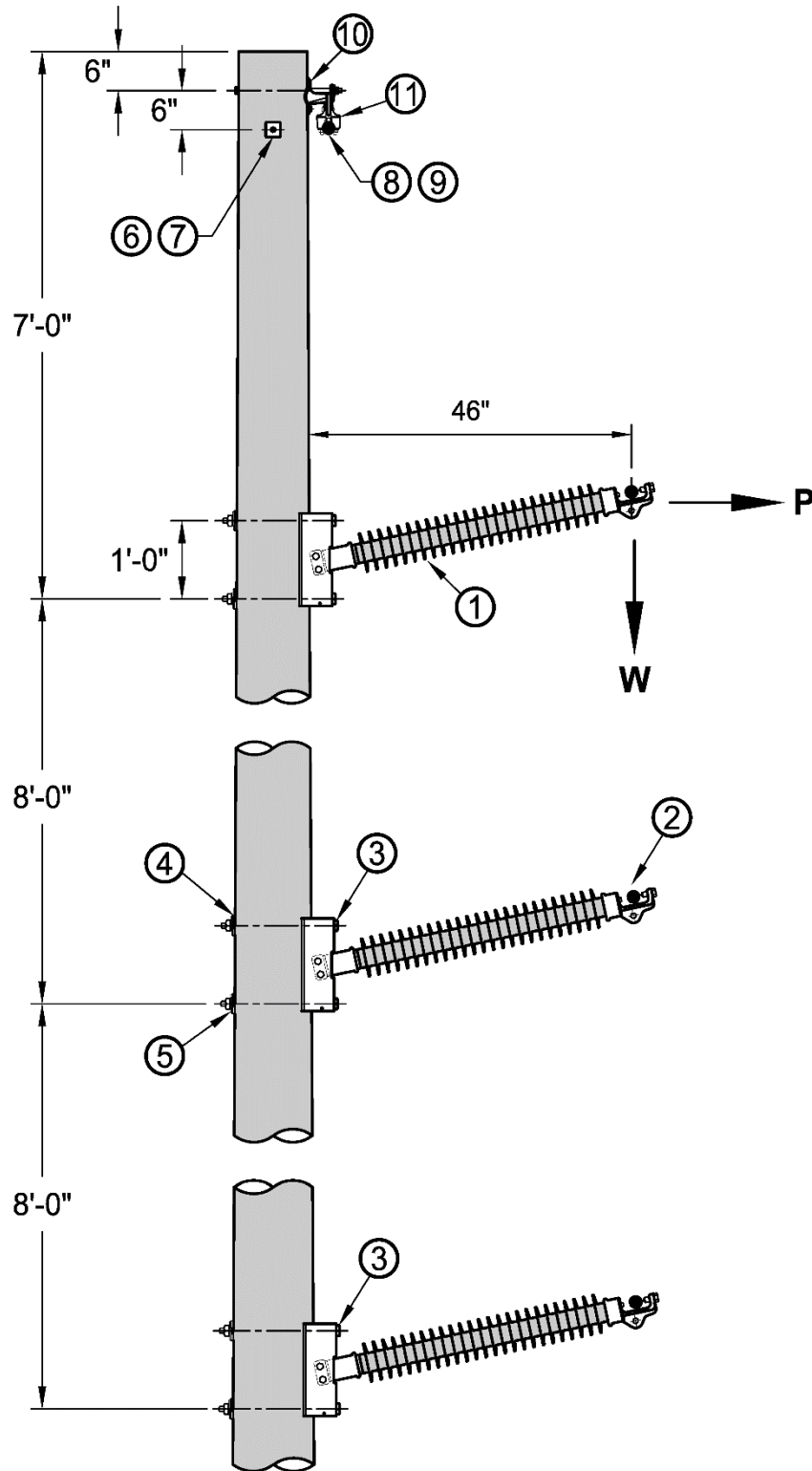
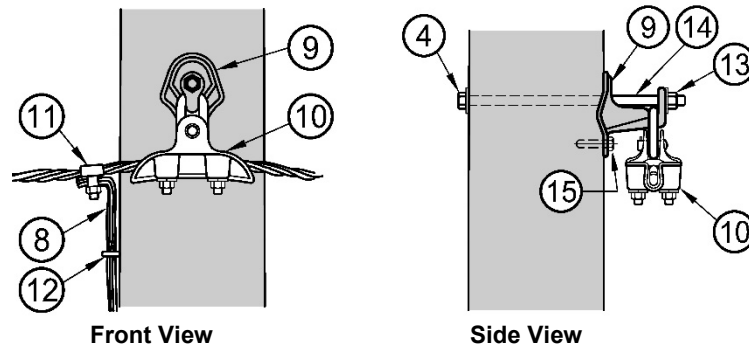

Figure 3h. 115 kV Vertical Tangent Pole, Top Assembly with Static Wire



- Notes:**
1. Maximum vertical weight (W) not to exceed 1515 lb.
 2. Maximum horizontal pull (P) not to exceed 2000 lb.

Figure 3i. Static Wire Framing Details



4. Construction Notes

Guys should be installed where appropriate on poles. See SCL 0199.01 for guying instructions.

Install line guards (Stock Nos. 658935, 658940, and 658946) where lines form an angle.

Install machine bolts with heads on insulator side; nuts, washers, and threads on the pole side.

Bolt lengths will vary depending on installation height. Bolts should be of the required length to fit the pole diameter at each point of installation. Bolts specified in the material list (Section 5) are sized appropriately for the majority of installation points. No more than two inches of bolt thread should be exposed after installation. Crews are encouraged to have a small supply of shorter lengths on hand for instances in which bolt length is excessive.

Install double coil spring washers on the threaded end of machine bolts.

Contact the SCL Design Engineer for concerns regarding the following:

- Poor soil conditions
- Avian and wildlife
- Salt spray
- Clearances

The static wire framing assembly is intended for Alumoweld 0.486-in diameter wire.

5. Material List

Table 5. Materials for 115 kV Tangent Pole Top Assemblies

Fig	Compatible Unit	ID	Quantity			
3b	115 kV Horizontal Tangent	PLT115-TAN				
3d, 3i	115 kV Horizontal Tangent with Static Wire	PLT115-TANSW				
3f	115 kV Vertical Tangent	PLT115-TAN				
3h, 3i	115 kV Vertical Tangent with Static Wire	PLT115-TANSW				
#	Material Description	ID				
1	Insulator, 115 kV, horizontal line post, polymer	690189	3	3	3	3
2	Clamp, trunnion, line post	695194	3	3	3	3
3	Bolt, machine, galvanized, sq. head, 3/4" x 22"	780880	6	6	6	6
4	Washer, square curved, 3/4", 3" x 3"	584947	7	6	7	6
5	Washer, double coil lock, helical, 3/4"	584267	6	6	6	6
6	Bolt, machine, galvanized, 5/8" x 14"	780846	1	1	1	1
7	Washer, square flat, galvanized, 2-1/4"	585135	1	1	1	1
8	Wire, #2/0, bare copper (ft)	610425	90	-	90	-
9	Bracket, ground wire	565005	1	-	1	-
10	Clamp, suspension, static wire	695015	1	-	1	-
11	Two-bolt tap, 2/0	669379	1	-	1	-
12	Staples, Copperweld, 1/2" x 2"	583261	40	-	40	-
13	Palnut #4532, galvanized, 5/8"	Non-stock	1	-	1	-
14	Bolt, machine, galvanized, 5/8" x 12"	780845	1	-	1	-
15	Lag bolt, 1/2" x 2"	785261	1	-	1	-
17	Plastic molding, 3/4" x 8'	012980	4	-	4	-

6. References

SCL Construction Standard 0199.01; “Requirements for Guying and Anchoring”

SCL Construction Standard 0462.10; “Grounding Electrodes for Overhead Ground Wire (OHGW)”

SCL Construction Standard 1621.20; “115 kV Angle Pole Top Assemblies”

7. Sources

Lin, Jimmy; SCL Engineer and subject matter expert for 1621.10

National Electrical Safety Code (NESC); C2-2012 Edition; Institute of Electrical and Electronics Engineers (IEEE) Inc., New York, NY, 2011

Neuansourinh, Ponet; SCL Standards Engineer, subject matter expert, and originator of 1621.10

SCL Construction Standard 1605.40; “115 kV Transmission Construction Using Polymer Insulators”