Guy Assemblies

1. Scope

This standard covers the requirements for assemblies for guys used to support Seattle City Light (SCL) distribution system wood poles.

Anchor materials and installation are outside the scope of this standard.

Guy installation is outside the scope of this standard.

2. Application

This standard is for SCL engineers, crews and contractor who design or install guys for wood pole structures.

It is assumed that users of this standard have prior knowledge and understanding of the subject matter.

3. Requirements

Guys are required on angle, deadend, and stub wood poles. The appropriate guy for the installation will be selected by an engineer. The following sections show the requirements for the installation of the various SCL guy configurations.

To determine the location of the primary insulator, measure the distance (D_p) between the primary conductor attachment to the lowest secondary or neutral conductor attachment. Take that measurement and subtract the length of any other insulator and deadend grips used to get the length of wire required. This is typically 6 ft on a 50-ft pole.

To determine the location of the secondary insulator, measure the distance (D_s) between the lowest secondary or neutral conductor attachment to the lowest communication conductor attachment. Take that measurement and subtract the length of the insulator and deadend grips used to get the length of wire required. This is typically 9 ft on a 50-ft pole.

Poles with fiberglass deadend assemblies are guyed the same way, except that the mounting hardware is already built into the fiberglass deadend assembly.



3.1 Down Guy

Down guys shall be installed as shown in figures 3.1a–d.

Figure 3.1a. 10M Primary Down Guy

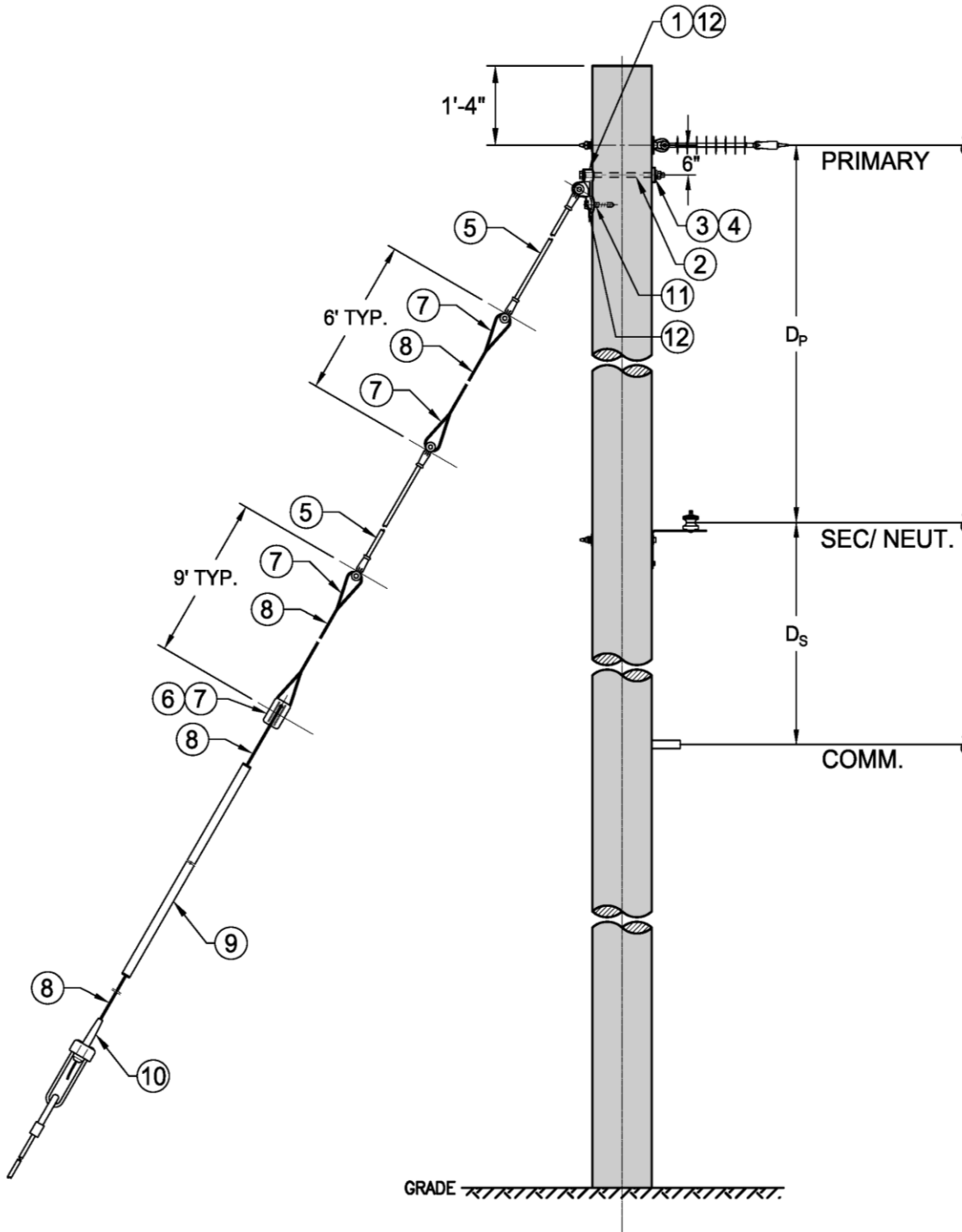

Figure 3.1b. 10M Secondary Down Guy

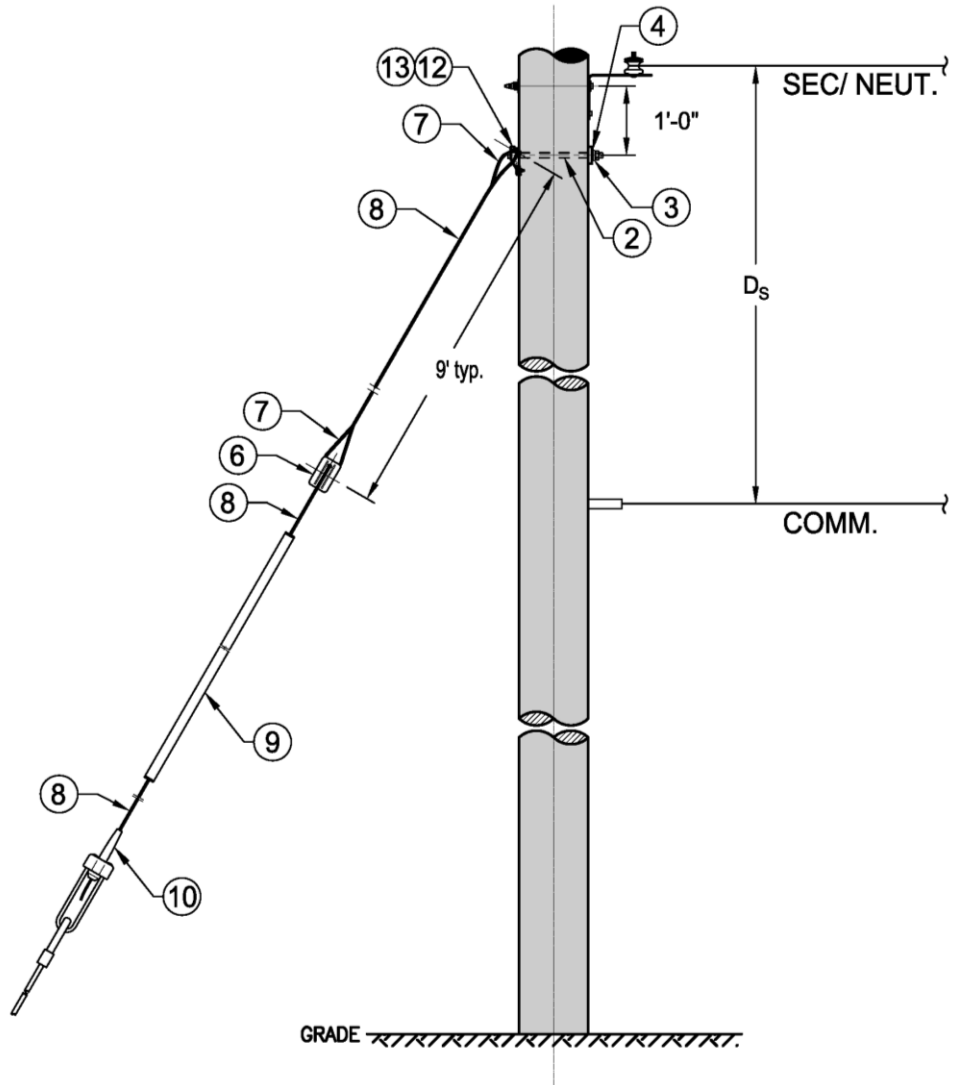

Figure 3.1c. 20M Primary Down Guy

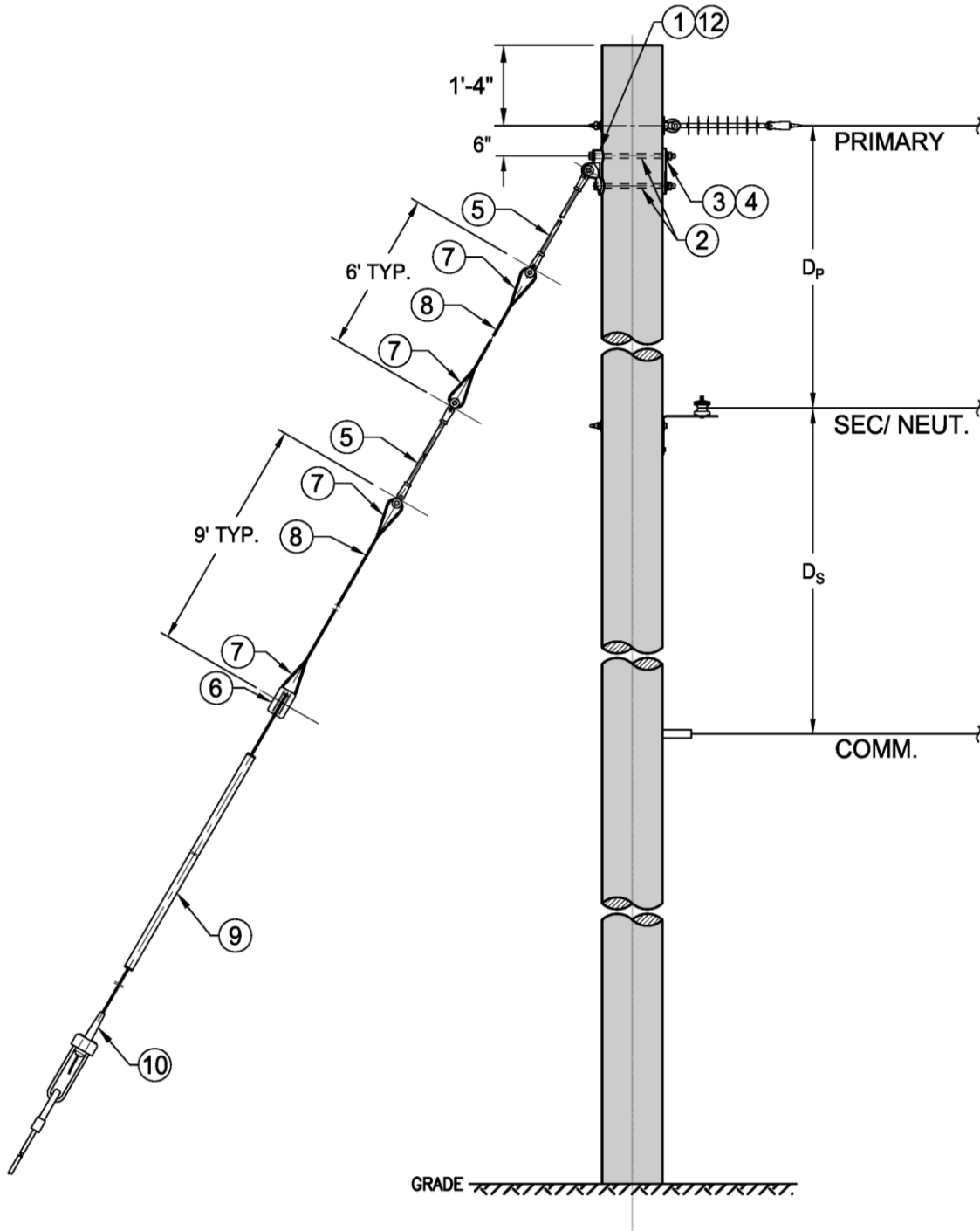
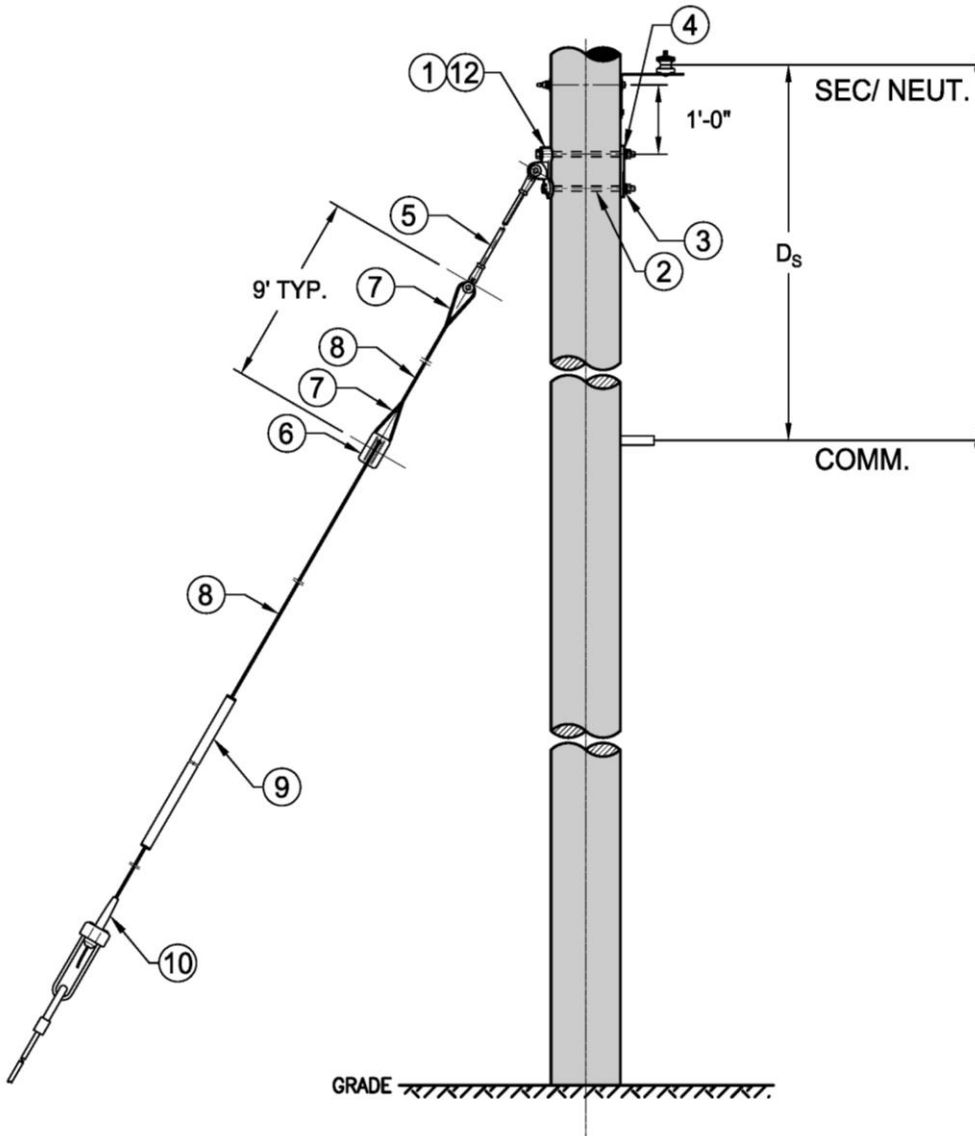

Figure 3.1d. 20M Secondary Down Guy



3.2 Span Guy

Span guys shall be installed as shown in figures 3.2a–d.

When attaching a span guy to a stub pole, a stub guy shall also be installed as described in Section 3.3.

If two span guys are required, guy hooks or plates shall be installed on the stub with a minimum 6-in spacing between connection points.

Figure 3.2a. 10M Primary Span Guy

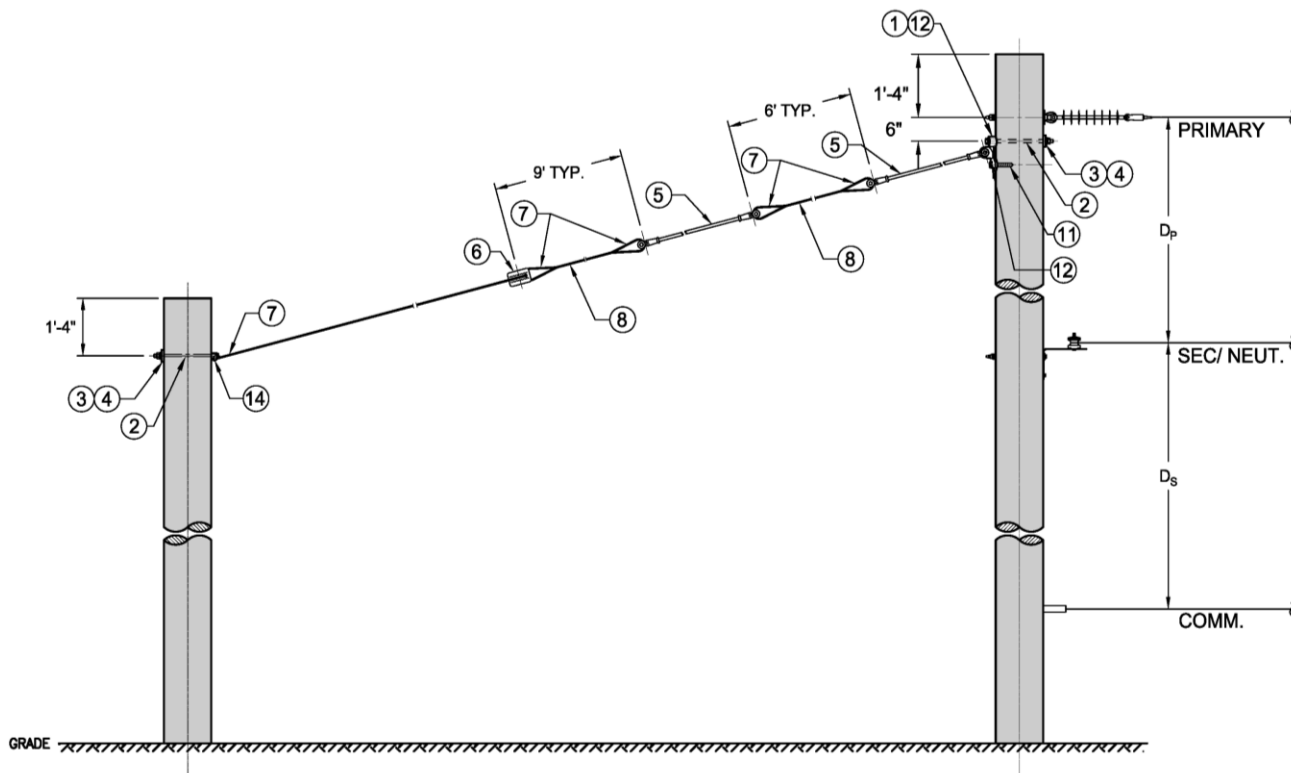

Figure 3.2b. 10M Secondary Span Guy

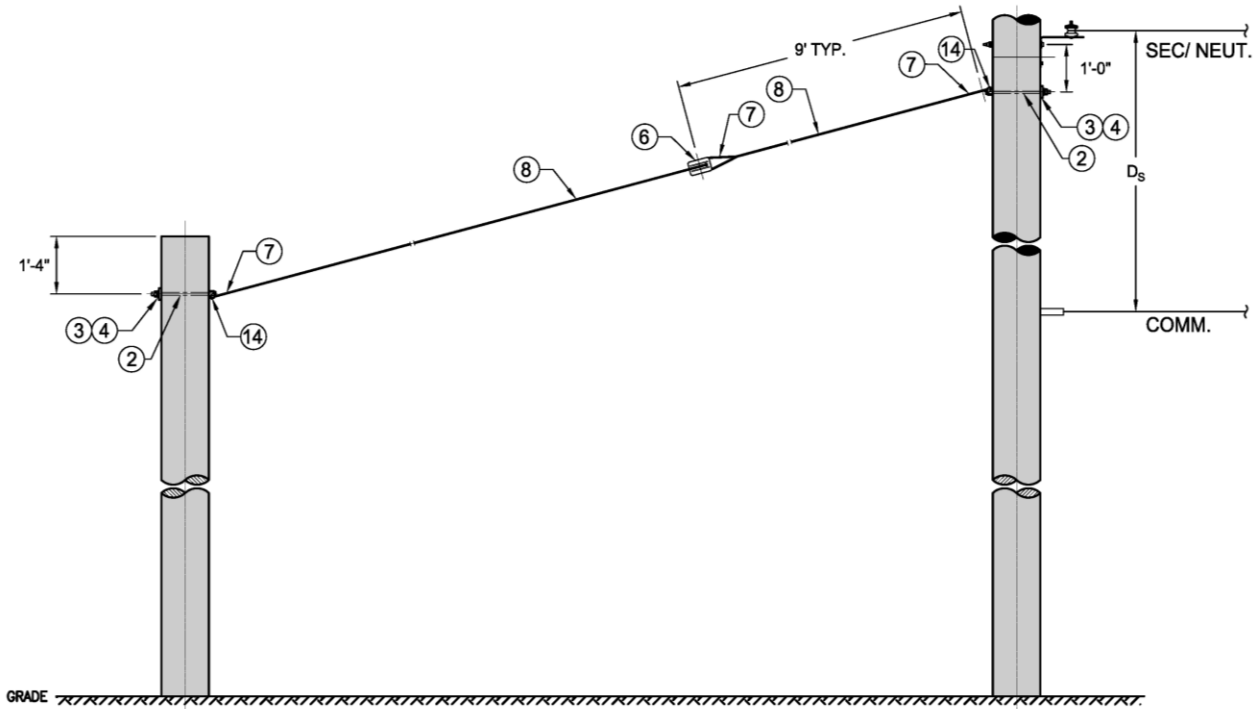

Figure 3.2c. 20M Primary Span Guy

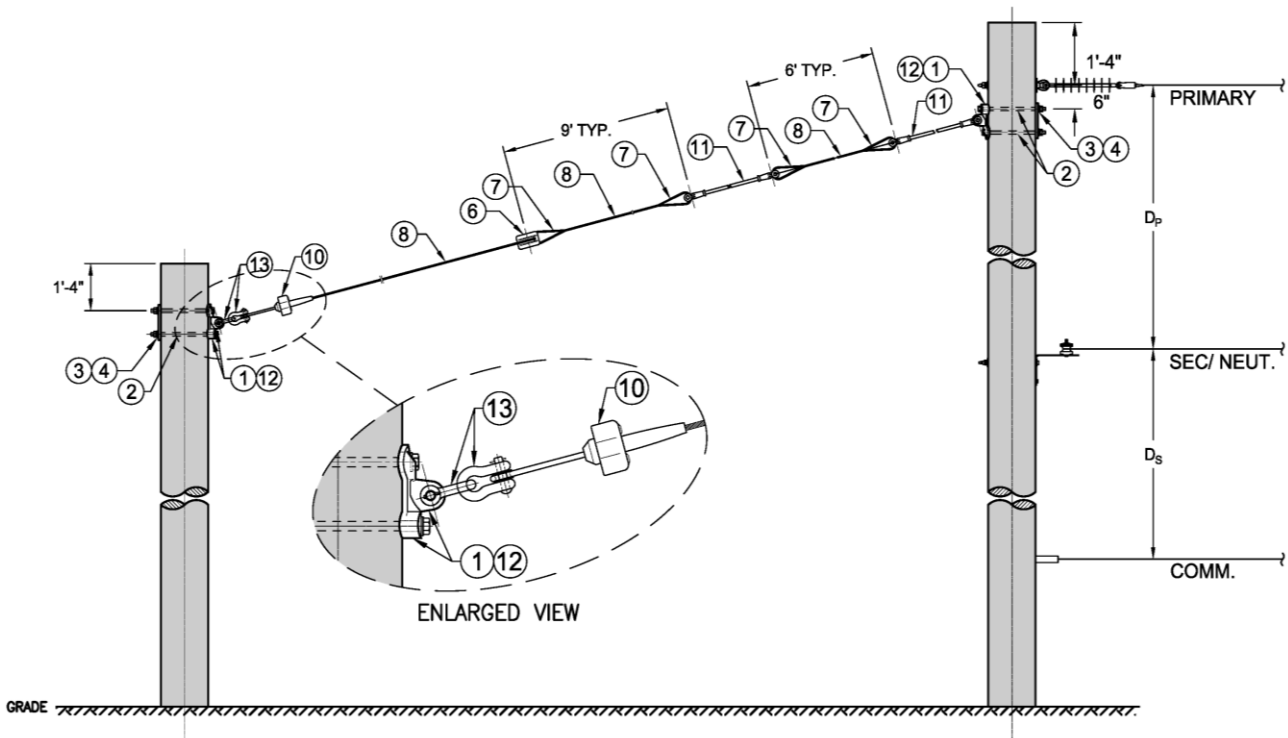
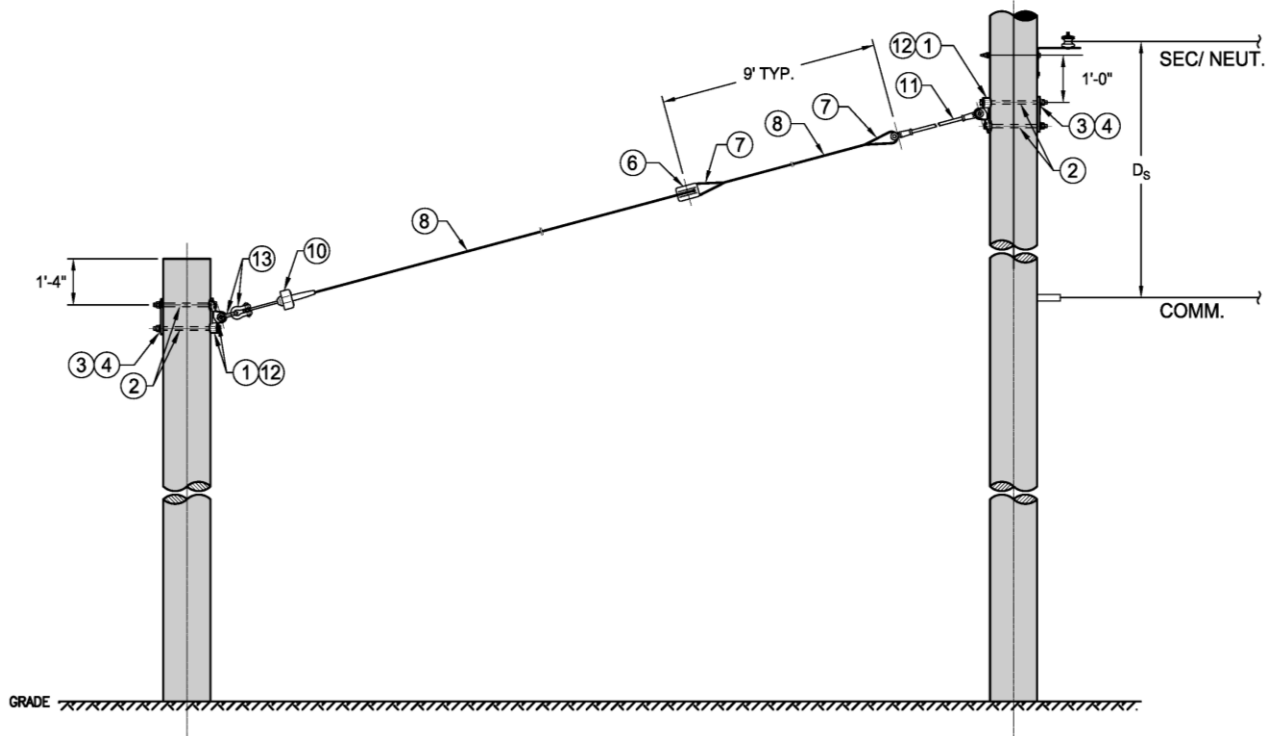

Figure 3.2d. 20M Secondary Span Guy



3.3 Stub Guy

Stub guys shall be installed as shown in figures 3.3a and 3.3b when a stub pole is used along with a span guy.

Figure 3.3a. 10M Stub Guy

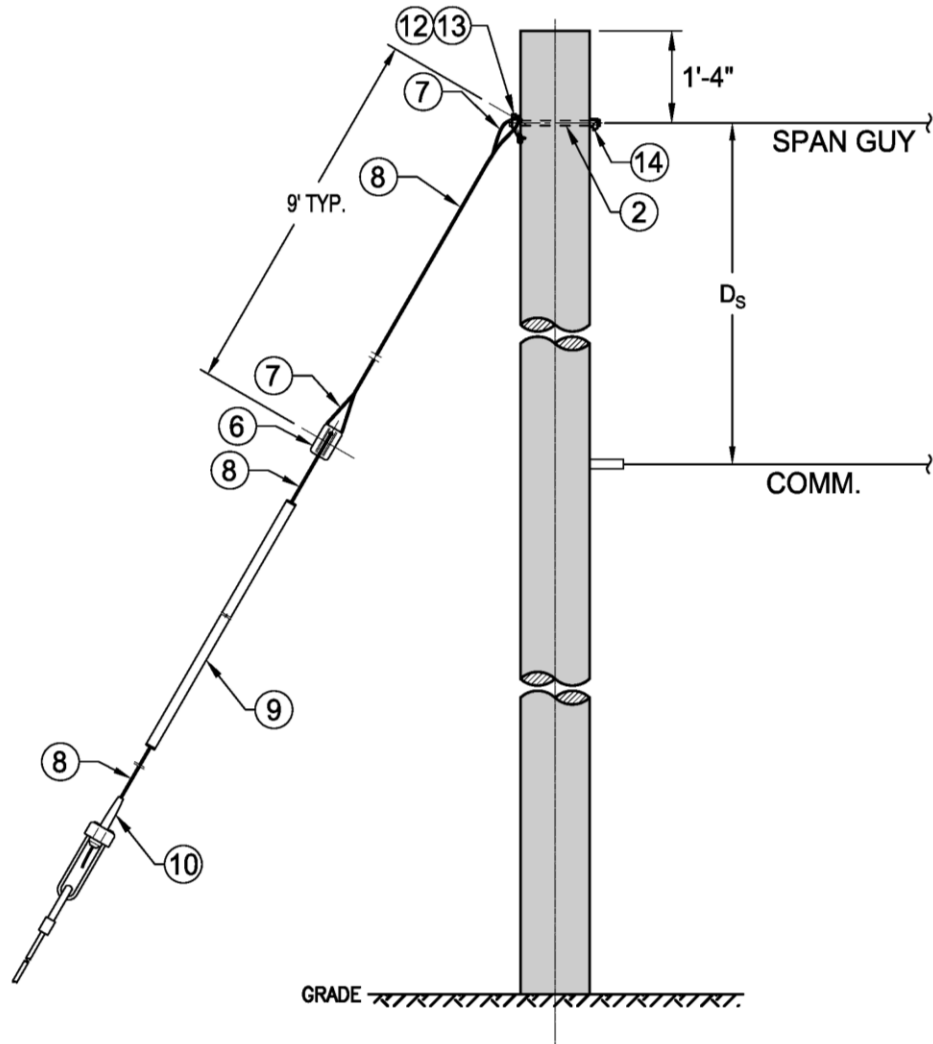
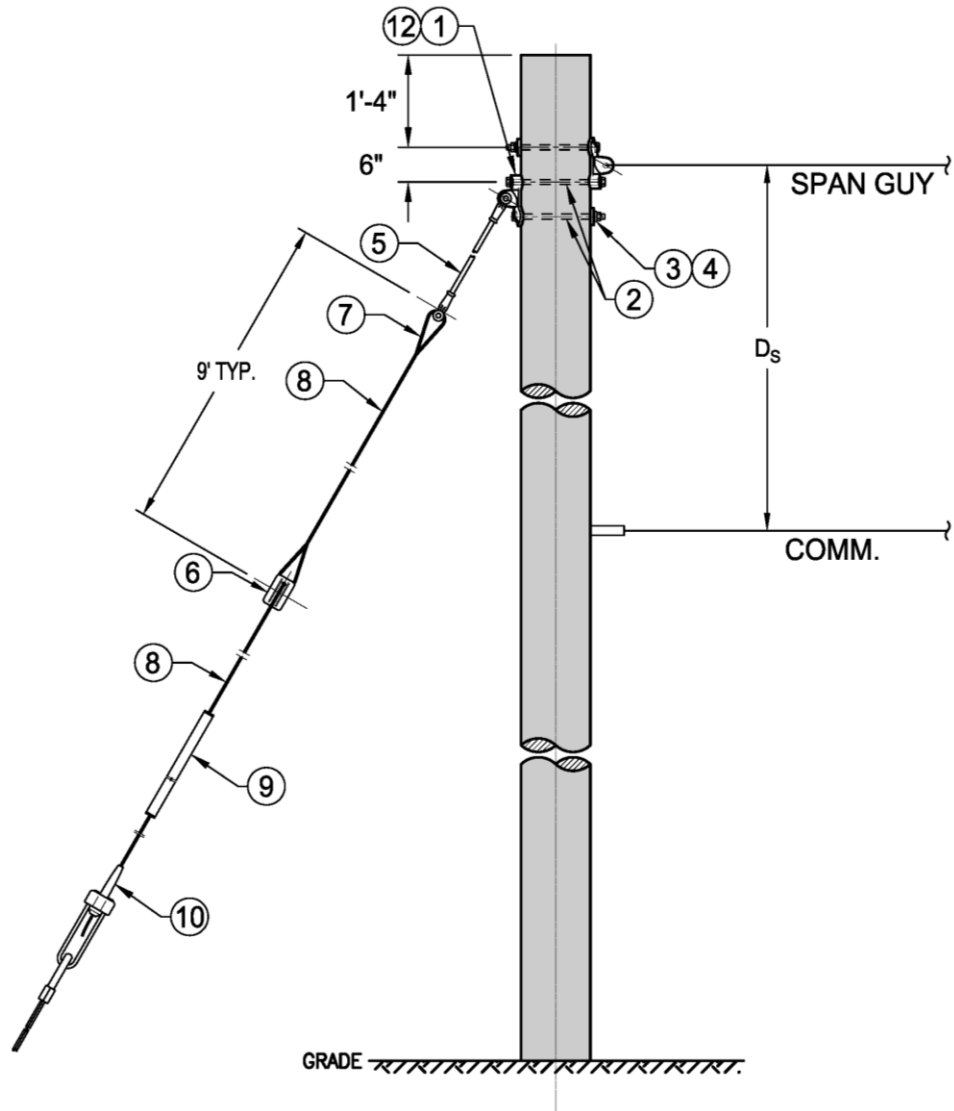

Figure 3.3b. 20M Stub Guy



3.4 Pipe Brace Guy

Pipe brace guys shall only be used with 10M guy wire and installed as shown in figures 3.4a and 3.4b.

Figure 3.4a. Primary Pipe Brace Guy

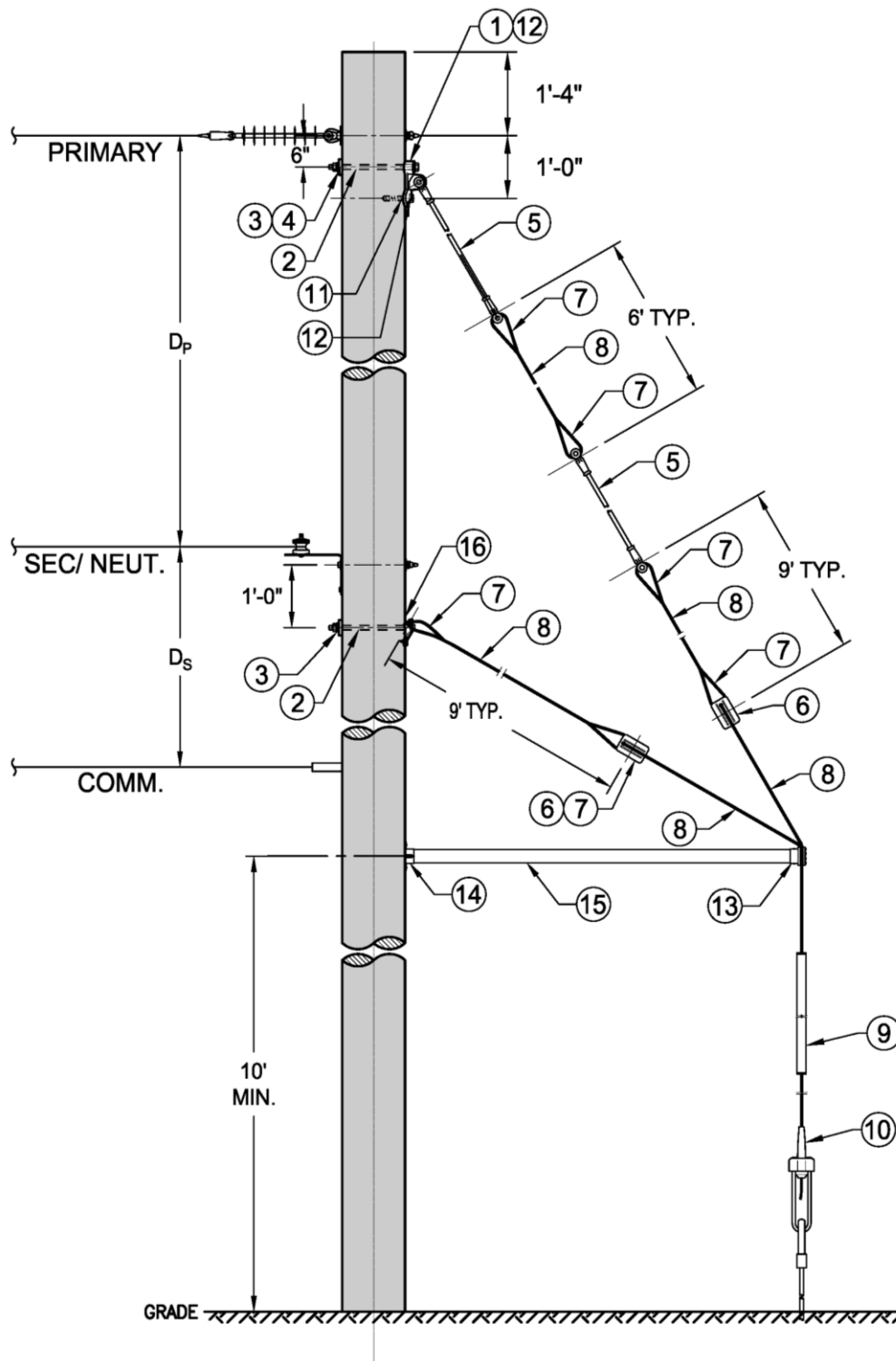
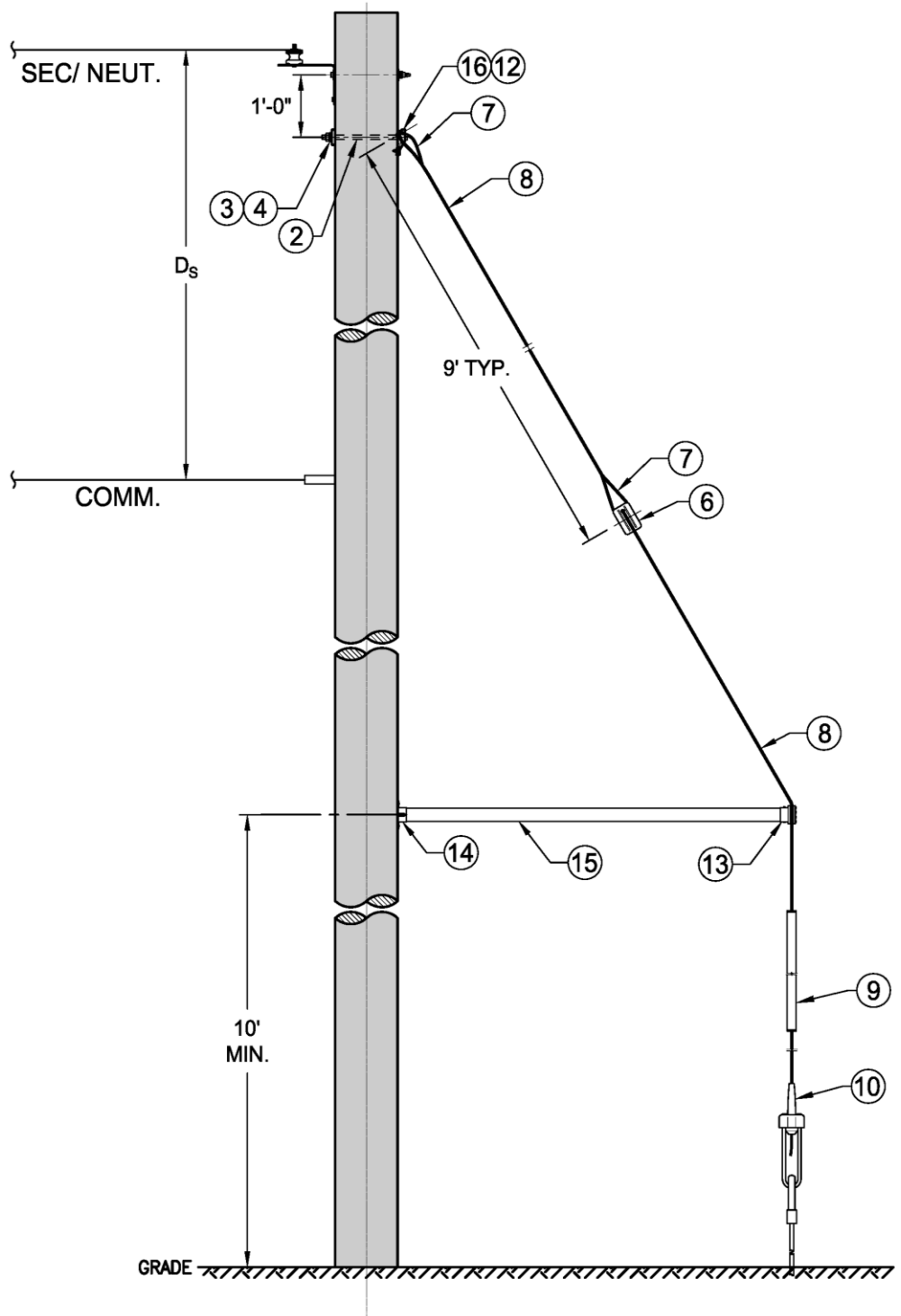

Figure 3.4b. Secondary Pipe Brace Guy



4. Construction Notes

Guy markers shall be installed as close to the automatic deadend as possible such that no guy wire is exposed.

The donut used for the shackle assembly in the 20M span guy is taken from the insulator rod on the high side of the guy.

5. Material Lists

Table 5a. Guy, 10M

Fig	Compatible Unit	ID	Quantity					
3.1a	10M Primary Down Guy	GUY10M-DWN-PRI	_____					
3.1b	10M Secondary Down Guy	GUY10M-DWN-SEC	_____					
3.2a	10M Primary Span Guy	GUY10M-SPAN-PRI	_____					
3.2b	10M Secondary Span Guy	GUY10M-SPAN-SEC	_____					
3.3a	10M Stub Guy	GUY10M-DOWN	_____					
3.1a	10M Primary Down Guy for FG Deadend Arm	GUY10M-D-PRI-FG	_____					

#	Material Description	ID	↓	↓	↓	↓	↓	↓
1	Plate, pole eye, hot dipped galvanized, 3/4"	565198	-	-	-	1	-	1
2	Bolt, machine, 3/4-10 x 14, hot dipped galv.	780876	-	-	2	1	1	1
2	Bolt, machine, 3/4-10 x 16, hot dipped galv.	780877	-	1	-	-	-	-
3	Washer, double coil lock, 3/4	584267	-	1	2	1	1	1
4	Washer, sq., 4 x 4 x 1/4, curved, 15/16" hole	584775	-	-	2	1	1	1
5	Insulator, guy strain, fiberglass, 12"	690092	2	-	-	3	-	2
6	Insulator, guy strain, porcelain	690104	1	1	1	2	1	1
7	Grip, deadend, 10M	565122	5	3	2	6	3	5
8	Guy wire, 10M	566406	80	80	120	120	80	80
9	Marker, guy, 8 ft, plastic, rigid PVC, yellow	565168	1	1	-	-	1	1
10	Deadend, guy, automatic, long 10M	565049	1	1	-	-	1	1
11	Lag screw, 4"	785261	-	-	-	1	-	1
12	Washer, round, 2", 3/4" diameter	585035	-	2	-	2	1	1
13	Guy hook, down	565195	-	1	-	-	1	-
14	Guy hook, span	014381	-	-	2	1	-	-

Table 5b. Guy, 20M

Fig	Compatible Unit	ID	Quantity					
3.1c	20M Primary Down Guy	GUY20M-DWN-PRI						
3.1d	20M Secondary Down Guy	GUY20M-DWN-SEC						
3.2c	20M Primary Span Guy	GUY20M-SPAN-PRI						
3.2d	20M Secondary Span Guy	GUY20M-SPAN-SEC						
3.3b	20M Stub Guy	GUY20M-DOWN						
3.1c	20M Primary Down Guy for FG Deadend Arm	GUY20M-D-PRI-FG						
#	Material Description	ID						
1	Plate, pole eye, hot dipped galvanized, 1"	565199	-	1	2	2	1	1
2	Bolt, machine, 7/8-10 x 14, hot dipped galv.	012637	-	1	3	3	2	2
2	Bolt, machine, 7/8-10 x 16, hot dipped galv.	012638	-	1	-	-	-	-
3	Washer, double coil lock, 3/4	584267	-	2	3	3	2	2
4	Washer, sq., 4 x 4 x 1/4, curved, 15/16" hole	584775	-	1	3	3	2	2
5	Insulator, guy strain, fiberglass, 35"	690090	2	1	-	-	1	2
6	Insulator, guy strain, porcelain	690106	1	1	1	1	1	1
7	Grip, deadend, guy, 7/16"	565124	5	3	3	5	3	5
8	Guy wire, AL-covered steel, 7/16" dia.	566408	80	80	120	120	80	80
9	Marker, guy, 8 ft, plastic, rigid pvc, yellow	565168	1	1	-	-	1	1
10	Deadend, guy, 8-1/8" bail, 7/16", automatic	565051	-	-	1	1	-	-
10	Deadend, guy, 17" bail, 7/16", automatic	565052	1	1	-	-	1	1
11	Insulator, guy strain, fiberglass, 24"	690096	-	-	1	2	-	-
12	Washer, Round, 2"	585035	-	2	3	3	2	2
13	Shackle, anchor, round pin	696618	-	-	2	2	-	-

Tab.5c. Guy, Pipe

Fig	Compatible Unit	ID	Quantity	
3.4a	Pipe Brace Guy, Primary	GUY10M-PIPE-PRI		
3.4b	Pipe Brace Guy, Secondary	GUY10M-PIPE-SEC		
#	Material Description	ID		
1	Plate, pole eye, hot dipped galvanized, 3/4"	565198	-	1
2	Bolt, machine, 3/4-10 x 14, hot dipped galv.	780876	1	2
3	Washer, double coil lock, 3/4	584267	1	2
4	Washer, sq., 4 x 4 x 1/4, curved, 15/16" hole	584775	1	2
5	Insulator, guy strain, fiberglass, 12"	690092	1	2
6	Insulator, guy strain, porcelain	690104	1	2
7	Grip, deadend, 10M	565122	3	8
8	Guy wire, 10M	566406	80	120
9	Marker, guy, 8 ft, plastic, rigid PVC, yellow	565168	1	2
10	Deadend, guy, automatic, long 10M	565049	1	2
11	Lag screw, 4"	785261	-	1
12	Washer, round 2"	585035	1	1
13	Fitting, clamp, 2-1/2", sidewalk pipe, guy	565054	1	1
14	Fitting, pole plate, 2-1/2", sidewalk pipe, guy	565105	1	1
15	Pipe, water, 2-1/2"., Sch. 40. galv. steel	710370	10	10
16	Guy hook, down	565195	1	1

6. Sources

- Lu, Curtis; SCL Standards Engineer and originator of 0199.01 (curtis.lu@seattle.gov)
- SCL Construction Standard D6-4 (canceled) ; "Guying and Anchoring"
- SCL Design Standard 9190.01; "Guying and Anchoring Requirements"
- SCL Design Standard 9190.03; "Guy Selection"