

Type 1 and Type 2 Open Bottom Handhole, Precast, Secondary and Streetlight



1. Scope

This standard covers the requirements for precast secondary handholes, streetlight handholes, handhole stacking risers, and handhole covers.

Stock No.	Description
014923	Type 1 assembled handhole, with frame and cover labeled "SL"
014917	Type 2 assembled handhole, with frame and cover, labeled "SCL"
014918	Type 2 assembled handhole, with frame and cover, labeled "SL"
014921	Type 2 handhole, with frame and no cover
014922	Type 2 handhole stacking riser, without frame or cover
014919	Type 2 handhole cover, labeled "SCL"
014920	Type 2 handhole cover, labeled "SL"

Tamper-proof covers are outside the scope of this standard. See SCL 7204.11.

2. Application

Handhole assemblies are used to construct the means to allow connections to be made for secondary service and streetlight located on pedestrian sidewalks.

H-20 rated frames and covers are for use in pedestrian sidewalks where an occasional car or light truck may inadvertently traverse, or side streets that see only light truck traffic.

3. General Requirements

This standard is to be used in conjunction with the latest version of SCL 7203.01, "Precast Reinforced Concrete Handholes, General Requirements."

Standard Coordinator
Sunny Kim



Standards Engineering Supervisor
John Shipek



Division Director
Andrew Strong



4. Industry Standards

All handholes shall meet the applicable requirements of the following industry standards:

City of Seattle Standard Plan 550a; “Handholes”; Public Utilities

WSDOT Standard Plan J-40.10-00; “Locking Lid Standard. Junction Box Types 1 & 2;”
 Washington State Department of Transportation

ASTM A123/A123M - 08; “Standard Specification for Zinc (Hot-Dip Galvanized) Coatings
 on Iron and Steel Products;” ASTM

ASTM A185/A185 – 07; “Standard Specification for Steel Welded Wire Reinforcement,
 Plain, for Concrete;” ASTM

ASTM A615/A615M - 09b; “Standard Specification for Deformed and Plain Carbon-Steel
 Bars for Concrete Reinforcement;” ASTM

ASTM C39 / C39M – 12; “Standard Test Method for Compressive Strength of Cylindrical
 Concrete Specimens;” ASTM

ASTM C478 – 11; “Standard Specification for Precast Reinforced Concrete Manhole
 Sections;” ASTM

ASTM C857 - 12a; “Standard Practice for Minimum Structural Design Loading for
 Underground Precast Concrete Utility Structures;” ASTM”

ASTM C858 - 10e1; “Standard Specification for Underground Precast Concrete Utility
 Structures;” ASTM

5. Requirements

The handhole shall meet Washington State Department of Transportation Standard Plan
 J-40.10 with the following clarifications.

Stock No.	Item	Type	Dimensions, nominal (in)				Height/ Thickness	Cover Label
			Inside Length	Inside Width	Outside Length	Outside Width		
014923	Handhole assembly with frame and cover	1	19	14	–	–	12	–
	Cover	1	–	–	17-3/4	12-3/4	5/16	“SL”
014917	Handhole assembly with frame and cover	2	28	17	–	–	12	–
	Cover	2	–	–	27-3/4	16-3/4	5/16	“SCL”
014918	Handhole assembly with frame and cover	2	28	17	–	–	12	–
	Cover	2	–	–	27-3/4	16-3/4	5/16	“SL”
014921	Handhole with frame	2	28	17	–	–	12	–
014922	Stacking riser	2	–	–	28	17	12	–
014919	Cover only	2	–	–	27-3/4	16-3/4	5/16	“SCL”
014920	Cover only	2	–	–	27-3/4	16-3/4	5/16	“SL”

Figure 5. Handhole

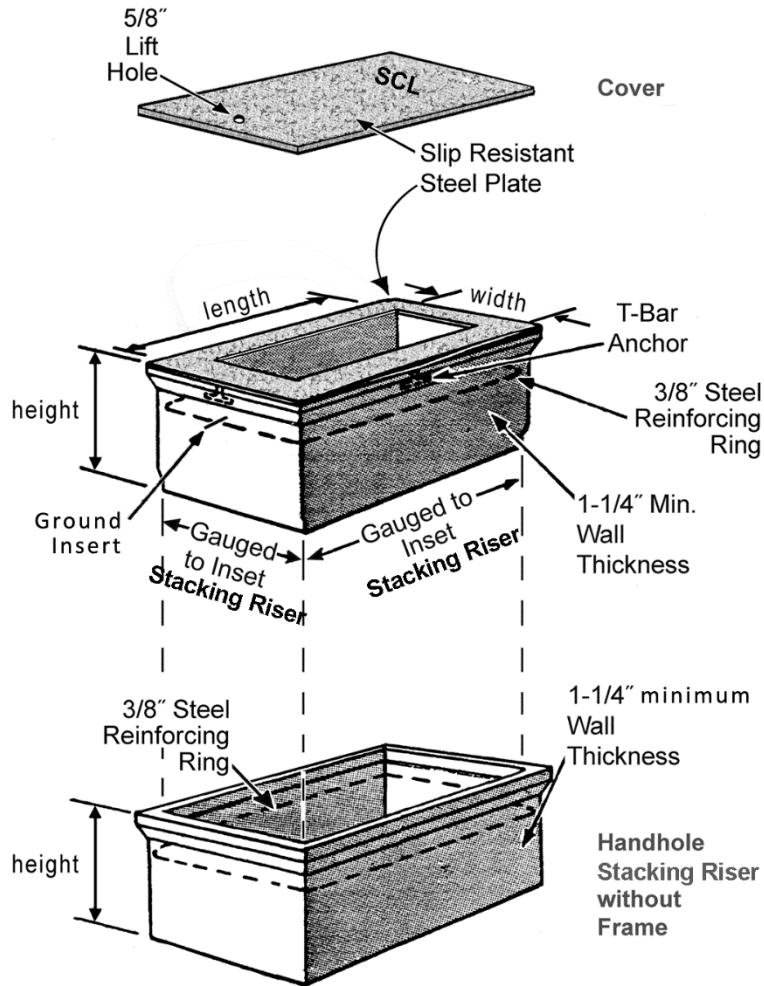

5.1 Precast Handhole

Precast secondary and streetlight handholes shall be of the general configuration shown, in accordance with City of Seattle Standard Plan 550a.

Handhole shall be designed to nest, with an easy, snug fit to increase the depth of the handhole when necessary.

Handhole shall be sound and free of cracks.

5.2 Concrete

The handhole shall be cast of concrete meeting a minimum strength of 4000 psi after 28 days.

5.3 Cover Plate

The cover plate shall adhere to the following requirements:

- The cover shall comply with City of Seattle Standard Plan No. 550a.
- The cover shall be 5/16-in (nominal) in thickness or other design pre-approved by Seattle City Light.
- The cover shall be at least H-20 rated.
- The cover shall have 1/16-in to 1/8-in clearance on each edge within the frame after galvanizing.

5.4 Frame

The frame shall adhere to the following requirements:

- The frame shall comply with City of Seattle Standard Plan No. 550a.
- The steel frame shall be securely anchored in the concrete.
- The frame shall have a ground point, which the copper braid from the cover may be attached.

5.5 Non Slip Surface

The cover and frame shall have a non-slip surface with the following properties:

- Slip resistant surface shall be coated with SlipNOT® Grade 3-coarse by W.S. Molnar Company, TH604 by Thermion, or have minimum coefficient of friction of 0.8.
- Bond strength shall be to the plate of 4000 psi or greater.
- Surface hardness shall be 55 minimum on the Rockwell "C" scale.
- The cover shall be identified on the underside with the type of surface ("S3" for SlipNOT® 3) and the year of manufacture. Example: "S3 2005." The identification shall be bead-welded or clearly stamped into a metal surface on the underside of each lid, or labeled with an adhesive metallic foil-backed label.

5.6 Grounding

A 4-ft length of copper braid, equivalent to a #8 AWG THNW or THHW copper wire, shall be secured from the handhole cover.

All handholes shall have a 5/16-in ground insert or a ground pad on the interior wall.

5.7 Labeling

Handhole covers shall be labeled "SCL" for secondary distribution service or "SL" for streetlight.

Label letters shall be affixed to the handhole cover by welding, engraving, or label plate in such a manner as to avoid being a tripping hazard.

5.8 Lock

The cover shall have a Penta-head bolt locking device to prevent easy removal by unauthorized persons.

5.9 Galvanizing

The frame, cover, label plate, and lettering shall be hot-dipped galvanized after fabrication in accordance with ASTM A123M.

6. Documentation

6.1 General

Documentation shall be in English and use customary inch-pound units.

Documentation shall use common industry terminology and well-understood abbreviations.

6.2 Technical Information

Upon request, the supplier shall provide the following technical information:

- Manufacturer name
- Manufacturing plant locations
- Product shop drawing

Technical information shall be presented in a clear and consolidated manner for ease of review.

7. Issuance

EA

8. Approved Manufacturers

Stock No.	Manufacturers	Description	Catalog Numbers
014917	H2-Pre-Cast Inc	Type 2 handhole assembly with frame and cover labeled "SCL" attached to handhole base	VJBOX-T2-SDOT-SCL
014918	"	Type 2 handhole assembly with frame and cover labeled "SL" attached to handhole base	VJBOX-T2-SNG-SCL-SL
014919	"	Type 2 handhole cover labeled "SCL"	BRJB-2SNL-SCL
014920	"	Type 2 handhole cover labeled "SL"	BRJB-2SNL-SL
014921	"	Type 2 handhole with frame and no cover	VBJSNSDOT
014922	"	Type 2 handhole stacking rise without frame or cover	VJBOX-T2R
014923	"	Type 1 handhole assembly with frame and cover labeled "SL" attached to handhole base	VJBOX-T1-SNG-SCL-SL

9. References

SCL Material Standard 7203.01; Precast Reinforced Concrete Handholes, General Requirements

SCL Material Standard 7204.11; "Covers, Tamper-Proof, for Type 2 Handholes"

10. Sources

9-34.6; Standard Specifications for Road, Bridge and Municipal Construction; City of Seattle; Public Utilities

Kim, Sunny; SCL Standards Engineer and subject matter expert for 7203.10

Smalley, Edward; SCL Engineer, Streetlights, and subject matter expert for 7203.10

Wang, Quan; SCL Standards Engineer, originator and subject matter expert for 7203.10