

## Photocontrol Receptacles with Mounting Bracket



### 1. Scope

This standard covers the requirements for photocontrol receptacles with mounting brackets.

This standard applies to Seattle City Light (SCL) Stock No. 568046.

### 2. Application

Photocontrol receptacles provide the connector interface for locking-type photocontrols.

Photocontrol receptacles, in conjunction with photocontrols, are used as light-sensing switches to control the lighting contactor controller (Stock No. 012776; SCL 5732.03).

Brackets are intended to be attached to the vertical surface of either crossarms, and wood or metal poles.

The product described in this standard is not intended for use as luminaire photocell receptacle in the SCL system.

### 3. Industry Standards

Photocontrol receptacles shall meet the applicable requirements of the latest revision of the following industry standards:

**ANSI C136.10**; American National Standard for Roadway and Area Lighting, Equipment—Locking-type Photocontrol Devices and Mating Receptacles—Physical and Electrical Interchangeability and Testing

**UL773**; UL Standard for Safety Plug-In Locking Type Photocontrols for Use with Area Lighting

Standard Coordinator  
Quan Wang

Standards Engineering Supervisor  
John Shipek

Division Director  
Andrew Strong

#### 4. Requirements

Photocontrol receptacles shall have the following attributes:

<b>Receptacle style</b>	Twist-locking type
<b>Color</b>	Black
<b>Socket style</b>	3-pin
<b>Line voltage (Vac), maximum</b>	480
<b>Load rating (A), maximum</b>	15
<b>Base housing material</b>	Phenolic
<b>Power contact material</b>	Brass or phosphor bronze
<b>Gasket material</b>	Thermal elastomer
<b>Receptacle dimensions (in), nominal</b>	2-9/16, dia. (socket), 2-1/2, height (See Figure 4)
<b>Wire leads</b>	3 - #14 AWG, color coded red (load), white (neutral), black (line), 12 inches minimum length
<b>Stem, threaded (in), nominal</b>	1/2, dia. x 5/8, long
<b>Mounting bracket material</b>	Aluminum or galvanized steel

**Figure 4. Photocontrol with Mounting Bracket Dimensions, Nominal**

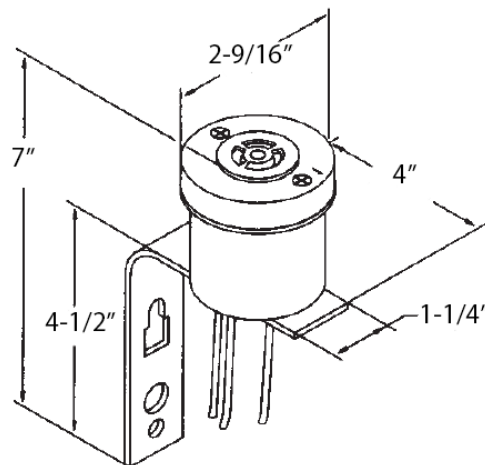

#### 5. Marking

Each photocontrol receptacle shall be marked with the following information:

- Manufacturer name
- Model number
- Voltage rating
- Load rating
- UL listing
- North orientation

#### 6. Packaging

Each photocontrol receptacle shall be packaged to prevent damage during shipping, handling, and storage.

Each standard package shall be legibly marked with the following information:

- Manufacturer identification
- Product description
- SCL stock number
- Quantity

Each shipping container shall be legibly marked with the following information:

- SCL purchase order number
- 

## 7. Issuance

Stock unit: EA

---

## 8. Approved Manufacturers

<b>Manufacturer</b>	<b>Catalog No.</b>
Fisher-Pierce Outdoor Lighting Controls	FPS476-71
Precision Control	M2A
Dark-to-Light (DTL)	DUR103
Ripley Lighting Controls	5927

---

## 9. References

**SCL Material Standard 5732.03**; "Lighting Contactor Controller"

---

## 10. Sources

**Borek, Tom**; SCL Streetlight Engineer, and subject matter expert for 5731.22

**SCL Material Standard 5693.2** (Canceled/renumbered); "Photoelectric Control Mounting Bracket"

**SCL Stock Catalog page 57-21**, June 11, 2018

**Vanderpool, Laura**; SCL Standards Engineering Technical Writer, originator, and subject matter expert for 5731.22.

**Wang, Quan**; SCL Standards Engineer and subject matter expert for 5731.22.

**[www.fpolc.com](http://www.fpolc.com)**

**[www.ripleylightingcontrols.com](http://www.ripleylightingcontrols.com)**

**[www.acuitybrands.com](http://www.acuitybrands.com)**

**[www.pmcontrols.com](http://www.pmcontrols.com)**