

## Customer Requirements for Padmount Transformer Services, Looped Radial System

---

### 1. Scope

This standard provides the requirements for Seattle City Light (SCL) looped radial system transformer pad services. This standard does not provide requirements for in-building vaults.

Requirements for in-building vaults are outside the scope of this standard.

For transformers located within in-building vaults, refer to SCL 0751.00 and 0751.60.

For transformers installed outside in below-grade vaults, refer to SCL 0732.50.

---

### 2. Application

This standard provides direction to customers, contractors, and SCL crews about where and how to properly install padmount transformer services and construct structures around transformers.

Single-phase pad-mounted transformers are only for replacing units that have failed in service. For new construction, consider installing a submersible-type unit instead. See SCL 4320.00.

---

### 3. Conflict

Where conflict exists between SCL requirements, the following order of precedence shall apply:

1. Project-specific Customer Requirements Package, including the Service Construction Letter and Drawing
  2. SCL 0724.50
  3. Seattle Building Code, 2015, Section 428 (within the City of Seattle)
  4. Other SCL construction standards
  5. Other industry standards
- 

### 4. General Requirements

See project-specific construction package for:

- Transformer pad location
- Bollards, if required

Conduits shall extend 3 inches above the surface of the pad.

Concrete seams shall be sealed with a product that is resistant to the transformer insulating fluid.

---

Standard Coordinator  
Brett Hanson



Standards Engineering Supervisor  
Brett Hanson



Division Director  
Bob Risch



Elbows shall be rigid galvanized steel.

All exposed metallic conduits shall have a grounding bushing or a bushing plus a ground clamp.

#### **4.1 High Voltage (Primary) Conduits**

**4.1.1** Provide and install two 4-inch conduits from the pad to the utility facility specified in the project-specific Customer Requirements Package. A maximum of 270 degrees of bends are allowed in the primary conduit run, unless otherwise specified in the project-specific Customer Requirements Package.

**4.1.2** Install and terminate below-grade conduit per SCL 0214.00 and 0222.02. If applicable, provide and install conduit risers on the pole per SCL 0224.34. Orientation and arrangement of conduit risers will be shown in the project-specific Customer Requirements Package.

#### **4.2 Secondary Conduits**

The customer shall furnish and install NEC-sized conduit and phase and neutral conductors of sufficient length to connect to the transformer terminals. See SCL 0473.50 for cable options. The conduit location shall be designated by SCL. If more than four conductors per phase and neutral are installed, the customer may be required to provide a secondary termination facility. For eight or more secondary conduits contact SCL Engineer for layout. See SCL 0224.07.

#### **4.3 SCL Access**

Provide properly supported, unobstructed access from the right-of-way to the transformer pad for SCL equipment-handling machinery. SCL must be able to move to the transformer pad, or remove from the transformer pad, all electrical equipment, including tall, heavy transformers, and to service electrical equipment using SCL equipment handling machinery.

Provide unobstructed clear space above each pad so that SCL can move transformers using SCL equipment handling machinery. Provide a permanent, level, unobstructed, 8-ft wide working area to the pad. If any portion of the building extends within 3 feet of the footprint of the pad, an Equipment Transportation Agreement is required that will be attached to the property title. The agreement requires the building owner to move transformers to and from the transformer pad, to a mutually agreed upon location on, or in the vicinity of, the owner's property from which SCL is able to deliver or pick up the transformers using normal transporting methods and equipment. Any damage that occurs to the transformers during transportation by the building owner and any additional expense incurred as a result of damage shall be paid by the building owner.

#### **4.4 Transformer Pad Location**

Pad shall be located in order to satisfy Figures 4.4a, 4.4b, and 4.4c. Combustible and noncombustible structures are defined by the Authority Having Jurisdiction.

Provide a minimum of 10 feet of unobstructed, level working clearance on the conduit-opening side of the pad, and a minimum of 3 feet of unobstructed, level working clearance on the three other sides of the pad, for SCL crew's working-space and the pad's ground ring. If curbs are used for protection instead of bollards, any side of the transformer pad exposed to traffic shall have a continuous minimum 8-inch-tall structural curb installed 10 feet from the nearest edge of the pad.

Foundations, footings, structures, tanks, piping, etc. are not allowed within the footprint of the transformer pad, grounding ring, or oil containment system.

Maintain a minimum of 25 feet of unobstructed vertical working clearance from the top of the pad to any trees.

Transformer pad must be a minimum of:

- 10 feet from any property line between private properties.
- 10 feet from building doors or windows.
- 10 feet from combustible structures.
- 7 feet from noncombustible conductive (metal) structures.
- 3 feet from noncombustible nonconductive structures.
- 10 feet horizontally from any trees. The distance shall be measured from the tree's root ball to the nearest edge of the pad.

**Figure 4.4a. Noncombustible Structure, Plan View** (for combustible structures, see Figure 4.4c.)

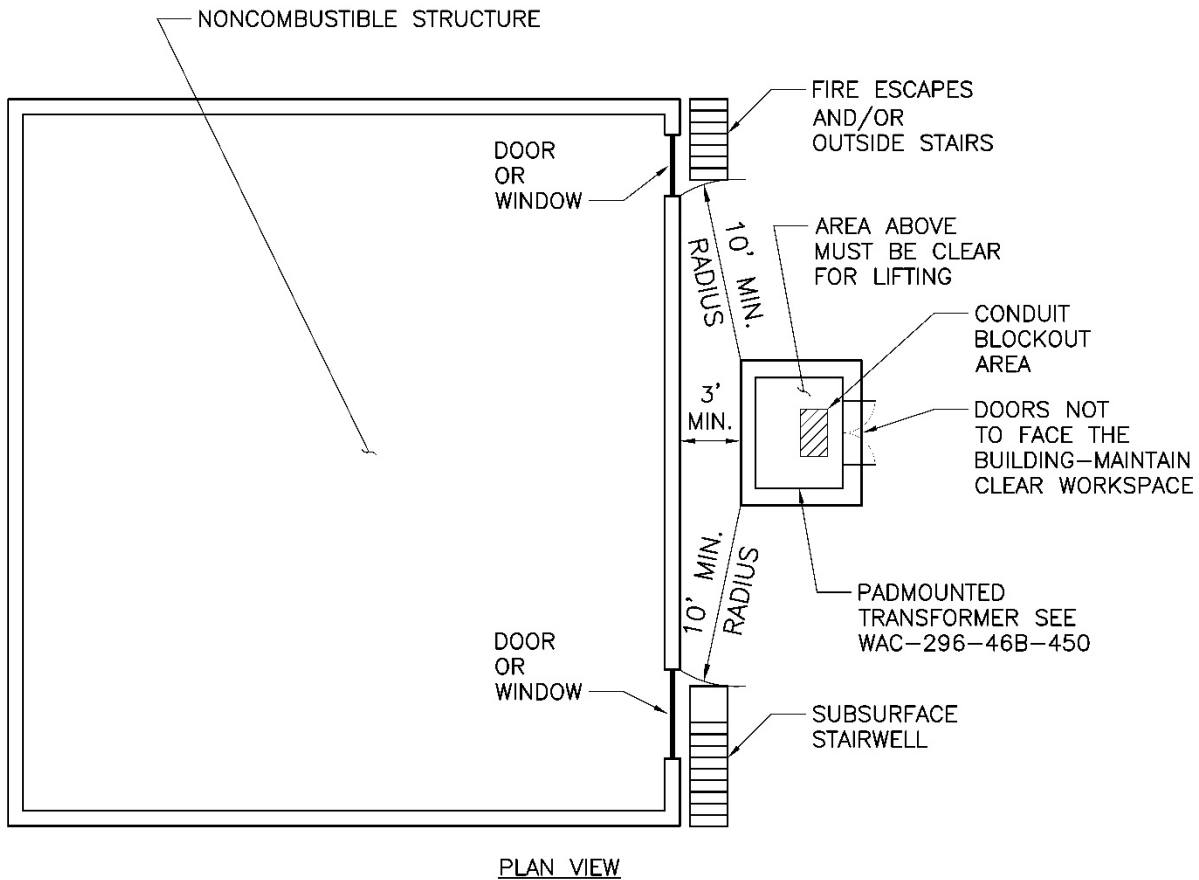

**Figure 4.4b. Noncombustible Structure, Elevation View** (for combustible structures, see Figure 4.4c.)

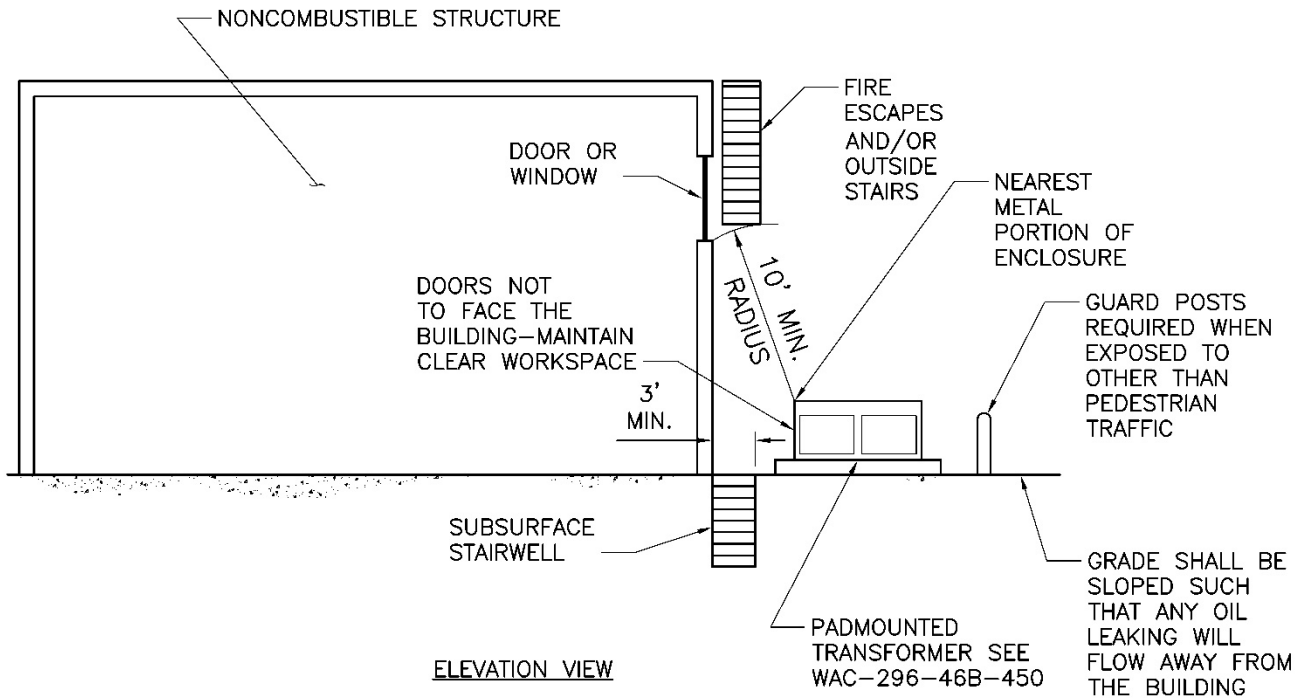

**Figure 4.4c. Combustible Structure, Elevation View**

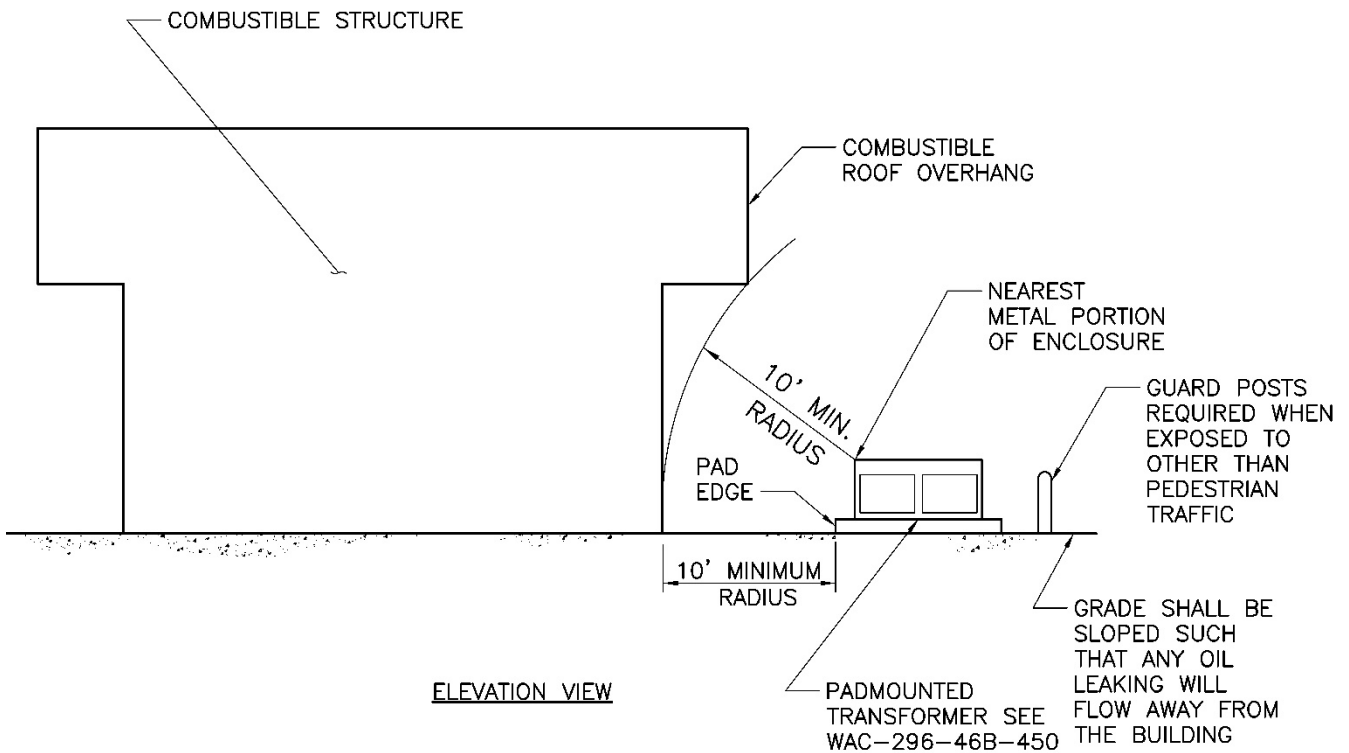

#### 4.5 Bollards

After the transformer has been set on the pad, install highly-visible, non-conductive 8-inch diameter minimum by 8-foot long rigid posts, Ceme-Tube Bollard or structural equivalent, to protect the transformer from vehicles. Insert posts to a depth of 4 feet and fill with concrete per manufacturer's instructions.

Locate bollards outside of the oil containment system.

Locate bollards a minimum of 4 feet away from the transformer door side of the pad so that the doors will open 180 degrees.

Locate bollards a minimum of 3 feet away from the transformer pad on the other three sides of the transformer.

See project-specific construction package for bollard locations. Install bollards no more than four feet apart.

#### 4.6 Soundproofing

Isolate transformer pad so that sound and vibration levels from transformers satisfy applicable laws and ordinances of the State of Washington, King County, and the appropriate municipality.

#### 4.7 Oil Containment

Provide oil containment per SCL 0735.50.

Seal all stranded ground wires entering the terminal compartment to form an oil stop barrier. See Figures 5a—5c.

If precast or cast-in-place oil-containment system is installed separately from the transformer pad, connect the pad to the system.

Connections shall be made with a minimum of eight (8) concrete anchors or rebar dowels: one near each corner and one at the middle of each side.

Connections shall be made a minimum of 6 inches from pad edges and 4 inches clear of the lifting inserts.

Rebar dowels or rod shall be embedded a minimum of 4 inches into the foundation or oil containment slab.

Concrete anchors shall be stainless steel (ASTM F593 - AISI 304/316 SS) and 3/4 inches minimum in diameter.

Rebar dowels or rods shall be stainless steel (ASTM F593 - AISI 304/316 SS) and #6 (nominal 3/4 inches) minimum diameter. The seam between the precast transformer pad and the oil containment system shall be grouted to prevent oil or water seeping into the interface.

## 5. Pad Requirements

Furnish and install pad, wire, ground rods, and connectors per Table 5 and figures 5a, 5b, or 5c.

If a cast-in-place pad is provided instead of precast, it shall meet the following requirements:

- Dimensions shall meet the minimum requirements of SCL 7203.76. Pad thickness can be increased to meet project conditions.
- Pad shall be designed for gravity and seismic load of transformer. Confirm dimensions and weights with SCL Electric Service Representative (ESR) and Electric Service Engineer (ESE).
- Cast-in-place concrete shall be designed per ACI 318.
- Concrete strength shall be  $f'c = 4500$  psi minimum.

Contractor shall provide pad reinforcement per ASTM A615 or A706 Grade 60, at quantities required by engineering calculations. At a minimum, provide the following:

- A minimum single layer of #4 rebar each way at a 9-inch maximum spacing.
- A minimum of two longitudinal, #4 rebar in the three narrow strips around the conduit blockout.

Pad drawing and calculations shall be designed and stamped by a qualified Professional Engineer licensed in the State of Washington and submitted to the SCL Electric Service Representative (ESR) or Electric Service Engineer (ESE) for review prior to construction.

**Table 5. Material List**

Item No.	Item	Figure		
		5a (retrofit only)	5b	5c
1	<b>Transformer Pad</b>			
	Dimensions (W x L, inches)	48 x 56	96 x 93	96 x 120
	Stock No., Matl Std 7203.76	013721	013723	013724
–	<b>Transformer</b>			
	120/240V (kVA Range)	25-167	N/A	N/A
	208Y/120V (kVA Range)	N/A	150-500	750-1000
	480Y/277V (kVA Range)	N/A	150-1000	1500-2500
2	<b>Ground Wire</b>			
	Trade Size	2/0 AWG	2/0 AWG	2/0 AWG
	Quantity (ft)	40	60	65
	Stock No., Matl Std 6103.90	610434	610425	610425
3	<b>Connector</b>			
	Stock No., Matl Std 6693.70	669379	669379	669379
4	<b>Exothermic Weld</b>			
	Quantity	4	4	4
	Stock No., Matl Std 6762.90	013580	013585	013585
5	<b>Ground Rod</b>			
	Quantity	4	4	4
	Stock No., Matl Std 6762.25	564238	564238	564238

**Figure 5a. Single-Phase Transformer Pad Requirements (not for new construction)**

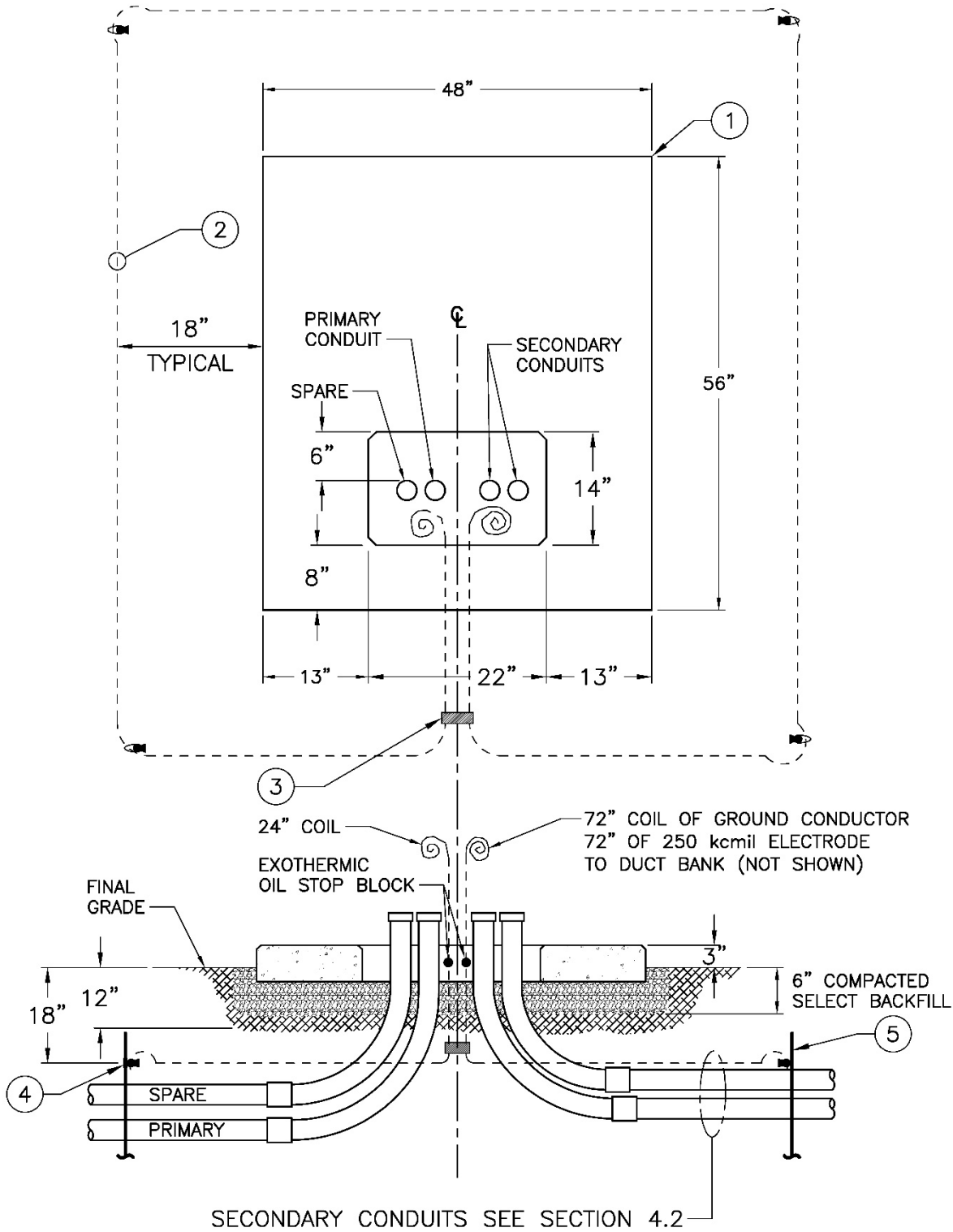

Note: Single-phase padmount transformers are not for new construction and are not available.

Figure 5b. Small Three-Phase Transformer Pad Requirements

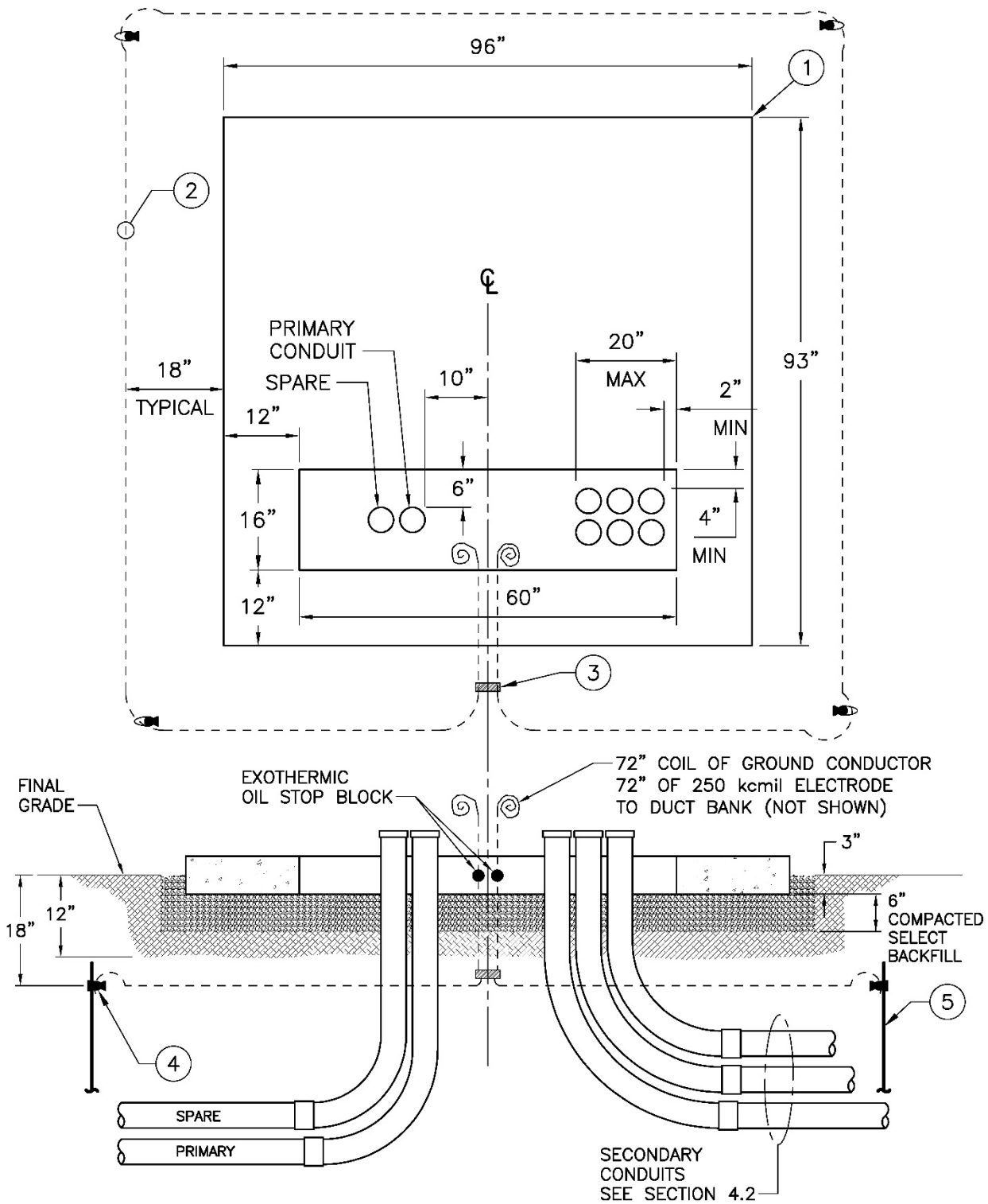



**Figure 5c. Large Three-Phase Transformer Pad Requirements**

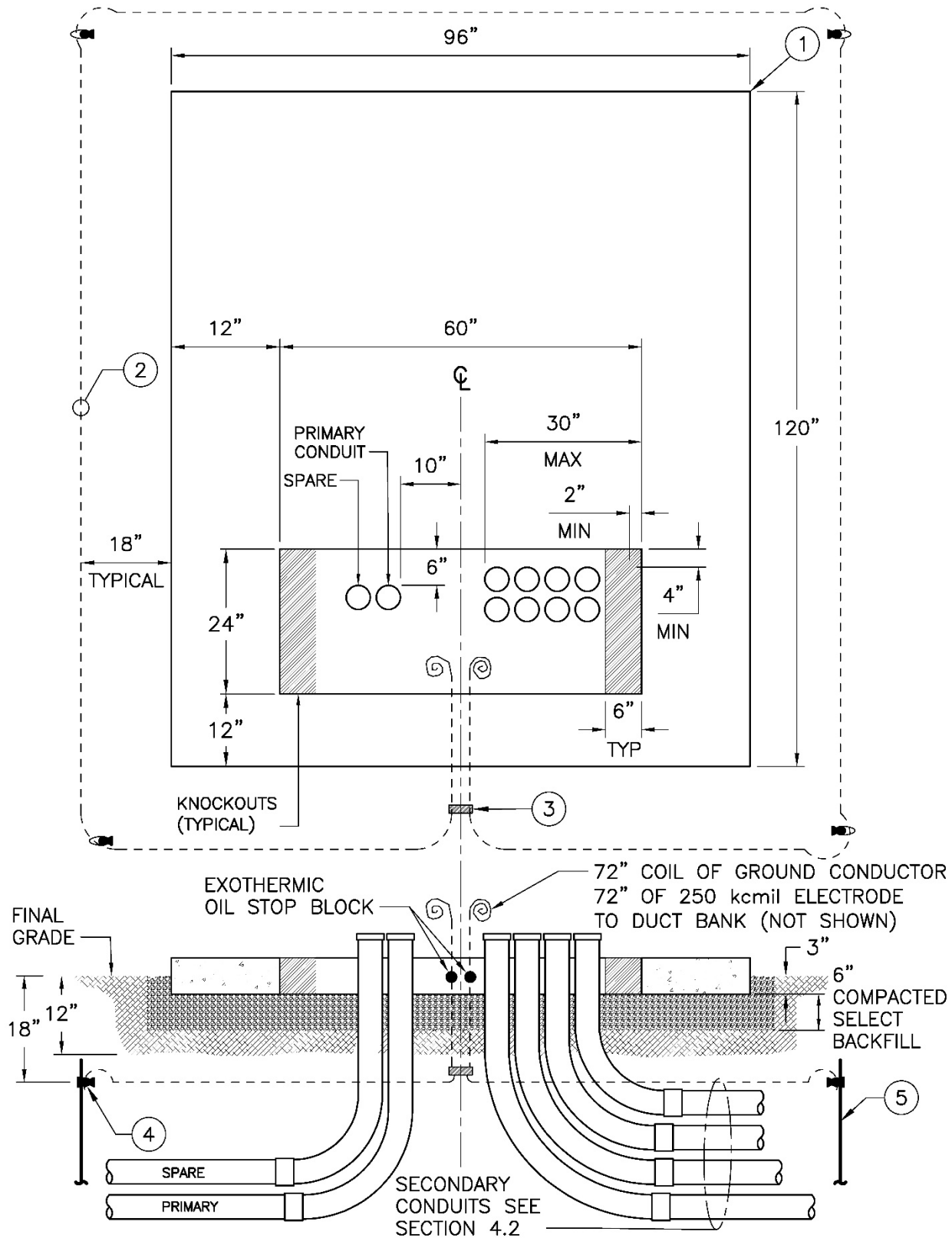

## 6. Grounding

Furnish and install grounding per Table 5 and figures 5a, 5b, or 5c.

Ground ring must form a complete rectangle as shown in Figures 5a, 5b, or 5c, and when tested by SCL, provide a resistance to ground of 25 ohms or less.

All below-grade connections shall be done by exothermic weld per SCL 0468.90.

For the primary conduit duct bank that enters the transformer terminal compartment, install 50 ft of bare 250 kcmil wire in the bottom of that duct bank to form a concrete-encased electrode. Wire must be straight and positioned to ensure it is surrounded by 2 inches of concrete on all sides when concrete is poured. From the duct bank electrode, extend 6 ft of additional wire into the transformer primary terminal compartment to connect it to the transformer grounding lug.

---

## 7. References

**ACI 318-19**; "Building Code Requirements for Structural Concrete and Commentary"

**ASTM A615/615M**; "Standard Specification for Deformed and Plain Carbon-Steel Bars for Concrete Reinforcement"

**ASTM A706/A706M**; "Standard Specification for Deformed and Plain Low-Alloy Steel Bars for Concrete Reinforcement"

**SCL Construction Standard 0214.00**; "Clearances between SCL Underground Structures and Other Structures"

**SCL Construction Standard 0222.02**; "Requirements for Primary Conduit and Duct Bank Installation"

**SCL Construction Standard 0224.07**; "Requirements for Secondary Conduit Installation"

**SCL Construction Standard 0224.34**; "Steel Conduit Risers"

**SCL Construction Standard 0468.90**; "Exothermic Connection System"

**SCL Construction Standard 0473.50**; "Looped Radial and Network Service Entrance Cables in Conduit for Underground Primary Service"

**SCL Construction Standard 0732.50**; "Customer Requirements for Below-Grade Transformer Service Vaults, Looped Radial System"

**SCL Construction Standard 0735.50**; "Oil Containment Systems"

**SCL Construction Standard 0751.00**; "Customer Requirements, In-Building Transformer Vaults, Network and Looped Radial Systems"

**SCL Construction Standard 0751.60**; "Concurrent Customer Requirements, In-Building Transformer Vaults"

**SCL Material Standard 4320.00**; "Submersible-Type, Single-Phase, Natural Ester Fluid, Distribution Transformers"

---

## 8. Sources

**Hanson, Brett**; SCL Standards Engineering Supervisor and originator of 0724.50

**Lin, Chung**; SCL Electrical Engineer and subject matter expert for 0724.50

**Perander, Eivind**; SCL Sr. Manager - Services, Standards & Streetlight Engineering and subject matter expert for 0724.50

**SCL Construction Guideline U10-7 (canceled)**; "Requirements for Transformer Pads and External, Below-Grade Transformer Service Vaults, Looped Radial System"

**SCL Construction Standard 0461.10**; "Grounding Electrodes for Handholes and Vaults"

**SCL Construction Standard 0652.01 (canceled)**; "Transformer Pad, Installation and Grounding, Single Phase, 25-167 kVA"

**SCL Construction Standard 0652.03 (canceled)**; "Transformer Pad, Installation and Grounding, Three-Phase, 150-300 kVA"

**SCL Construction Standard 0652.05 (canceled)**; "Transformer Pad, Installation and Grounding, Three-Phase, 500-1500 kVA"

**SCL Construction Standard 0652.07 (canceled)**; "Transformer Pad, Installation and Grounding, Three Phase, 2000-2500 kVA"

**SCL Material Standard 7203.76**; "Precast Reinforced Concrete Transformer Pads"