

Bolted Connections



1. Scope

This standard identifies the nuts, bolts, and washers required to electrically join standard two- and four-hole NEMA patterns of varying metals. Surface preparation is outside the scope of this standard. See SCL 0576.03.

2. Application

This standard is for Seattle City Light (SCL) engineers, crews, and contractors who install bolted connections.

Two-hole patterns are typically rated 600 A continuous. Four-hole patterns are typically rated 1200 A continuous. This standard is applicable for joining any combination of equipment terminal pads, drilled bus bars, conductor terminals. Copper salts will attack aluminum, whereas aluminum salts will not attack copper. Therefore, it is best to install, wherever possible, the aluminum conductors above the copper conductor. This will prevent the washing of copper salts over the aluminum. Split-ring washers are used to prevent nuts from backing off. Belleville washers are used to account for the expansion and contraction of different metals with temperature.

3. Requirements

Figures 3a through 3e show an assortment of configurations and the hardware required to make each connection.

The bolt assemblies in Figure 3a and 3b consist of one (1) stainless steel 1/2-inch 13 UNC bolt, one (1) stainless steel nut, two stainless steel flat washers, and one (1) Belleville spring washer.

Figure 3a. Aluminum to Copper

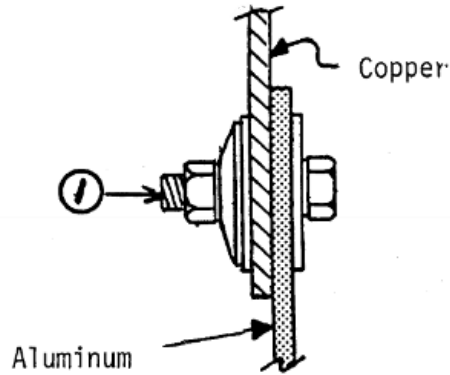

Figure 3b. Aluminum Lug to Aluminum Bus or Plate

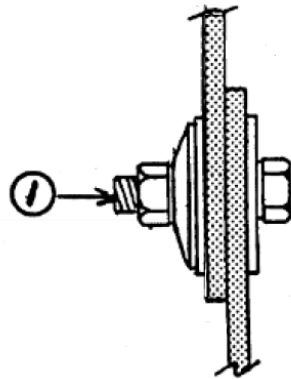

Figure 3c. Aluminum Lug or IWCB to Aluminum IWCB

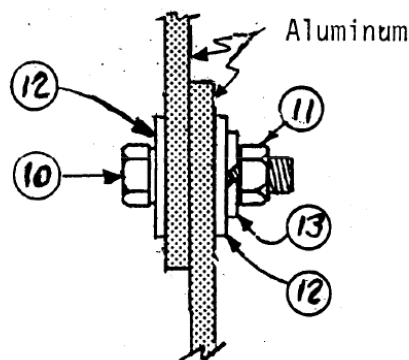

Figure 3d. Copper to Copper

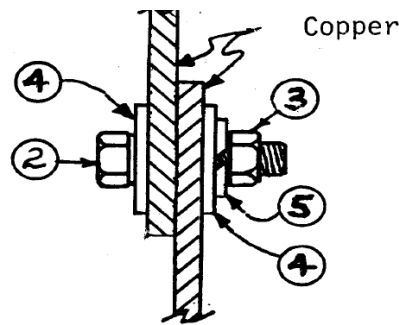
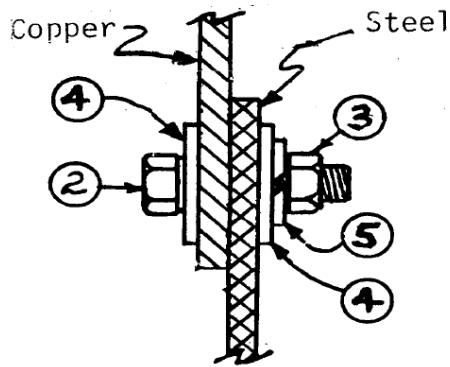

Figure 3e. Copper to Steel



4. Construction Notes

Longer bolts can be used in place of the ones specified.

For copper-to-aluminum connections, copper shall be on the nut side of the connection as shown in Figure 3a.

For copper-to-steel connections, steel shall be on the nut side of the connection as shown in Figure 3e.

Tighten connections to the torque values specified in Table 4.

Table 4. Torque Values in Foot-Pounds (ft-lb)

Bolt Size (in)	Aluminum	Silicon-Bronze	Stainless Steel
3/8	14	20	20
1/2	25	40	40
5/8	40	55	55
3/4	54	87	87

Aluminum bolt setups that are to be torqued require the application of a small amount No-Ox-Id (Stock No. 726181) on the threads for proper torque.

When using a Belleville washer with aluminum or steel bolts, tighten until the Belleville washer is flat as determined by a sudden stop. Do not back off.

5. Material List

Table 5a. Aluminum-to-Copper Connections

Fig	Compatible Unit	ID	Quantity					
3a	Double Al Lug - Double Cu Bus	JBOLT-SS1/2X2.5						
3a	Double Al Lug - Single Cu Bus	JBOLT-SS1/2X2.5						
3a	Single Al Lug - Double Cu Bus	JBOLT-SS1/2X2.5						
3a	Single Al Lug - Single Cu Bus	JBOLT-SS1/2X2						
3a	Double Cu Lug - Al Bus	JBOLT-SS1/2X2						
3a	Single Cu Lug - Al Bus	JBOLT-SS1/2X1.5						
#	Material Description	ID						
1	Bolt assembly, stainless steel, 1/2" x 1-1/2"	782042	2	-	-	-	-	-
1	Bolt assembly, stainless steel, 1/2" x 2	782040	-	2	2	-	-	-
1	Bolt assembly, stainless steel, 1/2" x 2-1/2"	782041	-	-	-	2	2	2

Table 5b. Materials for Aluminum Connections

Fig	Compatible Unit	ID	Quantity					
3c	IWCB/Plate - IWCB/Plate	JBOLT-AL5/8X2.5	-----					
3c	Double Al Lug - IWCB/Plate	JBOLT-AL5/8X3	-----					
3c	Single Al Lug - IWCB/Plate	JBOLT-AL5/8X3	-----					
3c	Al Bus - Al Bus	JBOLT-AL5/8X2	-----					
3b	Double Al Lug - Al Bus	JBOLT-SS1/2X2.5	-----					
3b	Single Al Lug - Al Bus	JBOLT-SS1/2X2	-----					
#	Material Description	ID	↓	↓	↓	↓	↓	↓
1	Bolt assembly, stainless steel, 1/2" x 2"	782040	2	-	-	-	-	-
1	Bolt assembly, stainless steel, 1/2" x 2-1/2"	782041	-	2	-	-	-	-
10	Bolt, hex, aluminum, 5/8" x 2"	781813	-	-	2	-	-	-
10	Bolt, hex, aluminum, 5/8" x 2-1/2"	781815	-	-	-	-	-	2
10	Bolt, hex, aluminum, 5/8" x 3"	781817	-	-	-	2	2	-
11	Nut, hex, aluminum, 5/8"	783560	-	-	-	2	2	2
12	Washer, flat, aluminum, 5/8"	788254	-	-	-	4	4	4
13	Washer, lock, split, aluminum, 5/8"	788274	-	-	-	2	2	2

Table 5c. Materials for Copper Connections

Fig	Compatible Unit	ID	Quantity				
3d	Cu Bus – Cu Bus	JBOLT-BR1/2X1.5					
3d	Double Cu Lug – Double Cu Bus	JBOLT-BR1/2X2					
3d	Single Cu Lug – Double Cu Bus	JBOLT-BR1/2X1.7					
3d	Double Cu Lug – Single Cu Bus	JBOLT-BR1/2X1.7					
3d	Single Cu Lug – Single Cu Bus	JBOLT-BR1/2X1.5					
#	Material Description	ID					
2	Bolt, silicon bronze, 1/2" x 1-1/2"	784587	2	–	–	–	2
2	Bolt, silicon bronze, 1/2" x 1-3/4"	784588	–	2	2	–	–
2	Bolt, silicon bronze, 1/2" x 2"	784589	–	–	–	2	–
3	Nut, hex, silicon bronze, 1/2"	783325	2	2	2	2	2
4	Washer, flat, silicon bronze, 1/2"	780026	4	4	4	4	4
5	Washer, lock, split, silicon bronze, 1/2"	788125	2	2	2	2	2

6. References

SCL Work Practice 0576.03; "Preparation for Bolted and Compression Connections"

7. Sources

ANSI/NEMA CC 1-2009; Electric Power Connection for Substations

Lu, Curtis; SCL Standards Engineer and Originator of 0575.02

SCL Construction Standard D14-4 (canceled)