

Network Area Requirements for Panel or Cast-in-Place Vaults

Figure 1, Typical Vault Installation

Vault configurations vary. Ring vaults are not acceptable in the Network area.

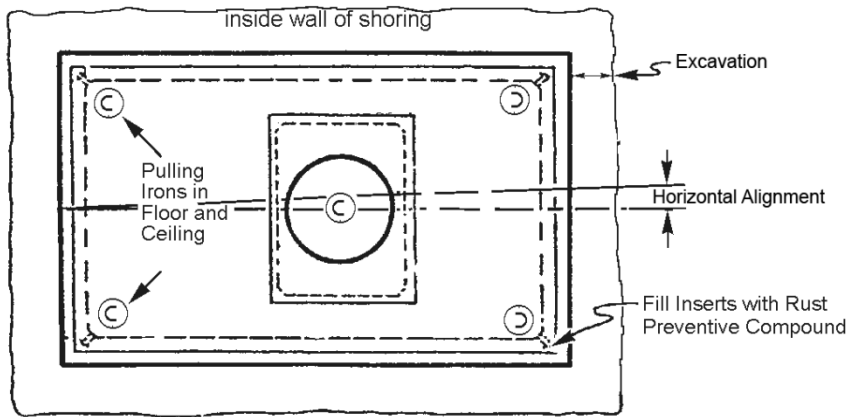

PLAN VIEW

Important:
 Do not put hatch in gutter or in alley center. If hatch must go in alley center, grade alley runoff around hatch (raise hatch as necessary - 2" maximum). Hinged vault hatches are not to be used in the Network area.

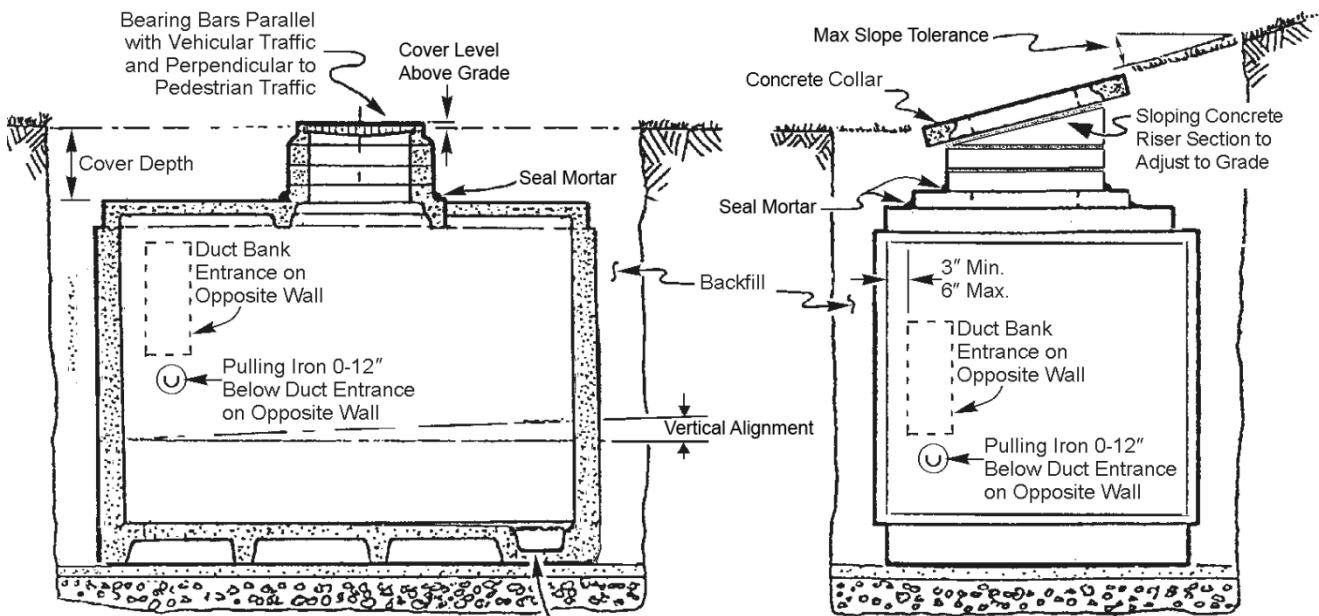

SECTION VIEW

END VIEW

Locate Sump
 Beneath Entrance
 Hatch

Standard Coordinator
 Brett Hanson

Standards Engineering Supervisor
 John Shipek

Division Director
 Andrew Strong

1. Codes

All work, including shoring and bracing, shall be in compliance with the latest editions of:

- 1.1 State of Washington Department of Labor and Industries WAC Chapter 296-46B-450, "Equipment for General Use – Transformers and Transformer Vaults"
- 1.2 State of Washington Department of Labor and Industries Chapter 296-155 WAC "Safety Standards for Construction Work"
- 1.3 Seattle Building Code Section 422 "Private and Utility Transformer Vaults"
- 1.4 SDOT Director's Rule 2004 – 02, "Street and Sidewalk Pavement Opening and Restoration Rules"

2. Excavation

- 2.1 Excavate so there is 36 inches between ends and sides of vault and the vertical sides of excavation or shoring unless larger excavation is authorized by the Engineer.
- 2.2 Remove shoring before backfilling.
- 2.3 If excavation bottom is saturated prior to placing bedding material, then over-excavate area as directed by the Engineer and place cobbles (3-inch to 8-inch stone — no broken concrete).

3. Bedding

- 3.1 The bedding material shall consist of 4 inches to 12 inches of stable base material, 1-1/4 inch minus gravel (Type 2).
- 3.2 If the excavation bottom is saturated or consists of inadequate bearing material, then over-excavate area as directed by the SCL engineer and place a construction geotextile at the bottom, then 12 to 24 inches of quarry spalls (Select backfill Type 17 or 27). See Figure 3.
- 3.3 If excavation bottom is not saturated and consists of adequate bearing material prior to placing bedding material, compact bottom of excavation with two full compacting operations at right angles to each other with a mechanical compactor.
- 3.4 Place a layer of crushed rock 1-1/4 inch minus gravel (Type 2), screed and compact to a minimum thickness of 4 inches and add 1/2 to 1-1/2 inches of sand (Type 6) to create a level surface.

Figure 3. Over-Excavation Detail

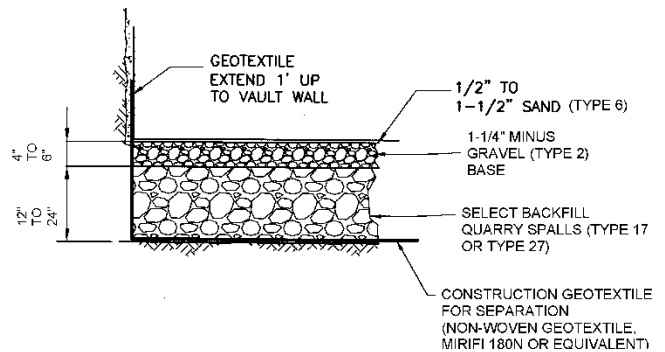

4. Vault Entrance

4.1 Hatch

- 4.1.1 For transformer vaults, the hatch shall be specified.
- 4.1.2 Personnel hatches shall be 42 inches round.
- 4.1.3 Covers for non-transformer vaults shall be H-20 solid unless otherwise specified.
- 4.1.4 Entrance and transformer openings for future transformer vaults shall be covered with H-20 solid covers until the transformers are installed.
- 4.1.5 Do not install hinged covers on permanent installations.
- 4.1.6 All covers (other than vented grates) shall have a slip-resistant surface, which has been approved by City Light Standards.
- 4.1.7 Where pulling problems are anticipated, such as pulling from both ends, it may be useful to design the vault with two hatches.

4.2 Hatch Location

- 4.2.1 Hatches shall not be in the gutter line or center of alley to protect electrical workers from surface water draining into the vault.
- 4.2.2 Put hatch 18 inches minimum away from curb line.

4.3 Hatch Relation to Vault Wall

- 4.3.1 The edge of the hatch openings shall be 36 inches from any vault wall, minimum.
- 4.3.2 Hatches shall be centered in vault ceiling if possible.

4.4 Grade and Risers

- 4.4.1 When adjusting the vault entrance to a sloping grade, install a sloping riser section and a poured-in-place collar. Do not use brick and mortar slope adjustments if possible. Minimize the use of mortar adjustments and in no case shall the mortar thickness exceed one inch. For in-street use, a properly engineered sloping riser section is required.
- 4.4.2 Whenever the final grade of the hatch exceeds 10% (6 degree slope), the hinge side of the personnel hatch shall be located on the downhill side.
- 4.4.3 Maximum slope of frame and grate shall not exceed 2 inches in 12 inches without permission of Engineer.
- 4.4.4 Set on riser in one inch of mortar (1 part cement to three parts sand with polyvinyl acetate bonding agent).
- 4.4.5 Where the riser section is specified at 12 inches deep or more, order a length of Unistrut cast into the side wall of the riser.

- 4.4.6 Adjust between 1/4 inch and 3/8 inch above grade to prevent water from entering vault, but not to cause a hazard. Ramp concrete to top of frame for gradual transition.

4.5 Frame

- 4.5.1 For transformer vaults the frame shall be specified.
- 4.5.2 Frames shall be H-20+ (extra heavy) suitable for bus traffic and special applications.

4.6 Concrete Collar

See SCL 0223.33.

5. Pulling Irons

- 5.1 All pulling irons shall be stainless steel.
- 5.2 All pulling irons shall be recessed; pulling irons in the vault floor shall be equipped with a flush removable cover.
- 5.3 If the vault has more than one personnel hatch, place pulling irons beneath each personnel hatch.
- 5.4 If a floor section seam is below the personnel hatch, place one pulling iron in each floor section.

Figure 5.1, plan views

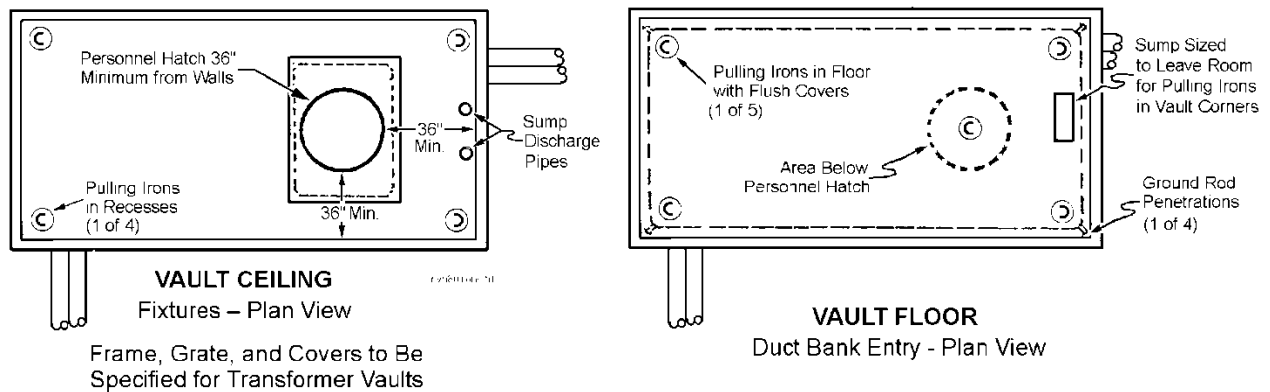
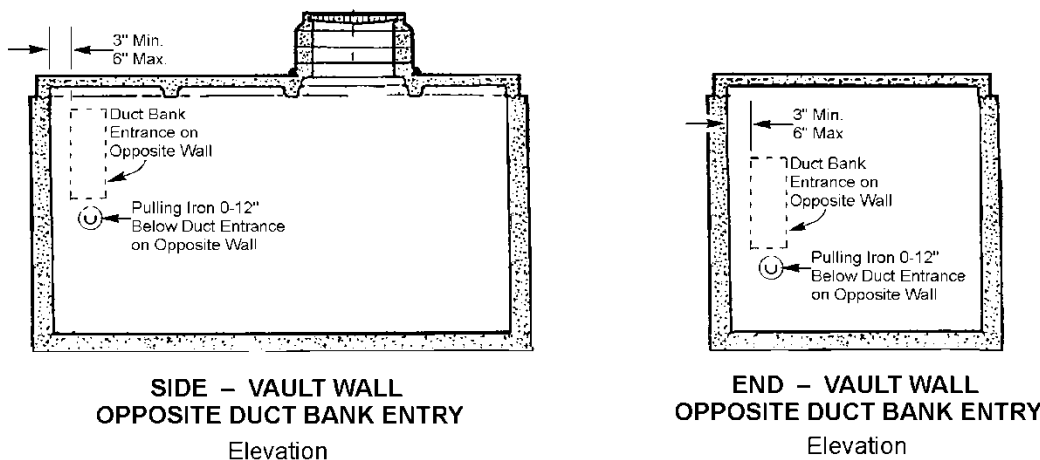

Figure 5.2, elevation views



5. Pulling Irons, continued

- 5.5** Install pulling irons in the following locations:
- 5.5.1 Each corner of the vault ceiling: 10,000 lb. working tension (40,000 lb. ultimate).
 - 5.5.2 Each corner of the vault floor: 10,000 lb. working tension (40,000 lb. ultimate)
 - 5.5.3 Below the personnel hatch: 10,000 lb. working tension (40,000 lb. ultimate).
 - 5.5.4 On each wall directly opposite a duct bank entry; place a pulling iron. These pulling irons shall be below, but not more than 12 inches below, the duct bank on the opposite wall. See illustration, above.
- 5.6** Pulling irons installed in walls shall have their working tension ratings stamped on the wall near them. Where possible, wall irons shall be rated at or above 10,000 pounds working tension.

6. Vault Installation

6.1 Vault Type

- 6.1.1 **Footprint:** No network vaults shall be specified smaller than 8 feet wide by 18 feet long (the size of a ring vault). Vaults and other facilities should be built to dimensions large enough to accommodate projected needs and not to the absolute immediate minimum.
- Below grade, cast-in-place, **transformer vaults** shall be 10 feet by 20 feet, minimum.
- 6.1.2 Precast, "Ring," or "Section" vaults shall not be installed in network areas.
- 6.1.3 **Cable Accommodation:** Where transformer vaults are designed with primary cable conduits entering the vault side wall (90° to the length of the vault), add two feet to the width of the vault to allow extra distance between the cable penetration wall and the transformer.
- Where vaults are designed for primary cables of 1,000 kcmil or greater, **no** vault shall be smaller than 10 feet wide by 18 feet long.
- 6.1.4 **Special Height Requirements:** To allow for setting transformers and network protectors, the height of vaults designed for 13 kV transformers shall be a minimum of 9 feet. For 26 kV transformers, the height minimum shall be 10 feet.

6.2 Setting Tolerances

- 6.2.1 Precast Panel Vault:
- a. Horizontal alignment: End to end $\pm 1/8$ in per 1 ft length of vault.
 - b. Vertical alignment: Precast panel vault floor shall be sloped toward the sump when possible. If vault floor cannot be sloped, bedding shall be even and slope toward the sump to insure proper drainage. Vertical slope downward $1/4 \pm 1/8$ in per 10 ft toward the sump.
- 6.2.2 Cast-In-Place Vault Floor:
- a. Horizontal alignment: End to end $\pm 1/8$ in per 1 ft length of vault.
 - b. Vertical alignment: Cast in place vault shall be designed and poured with a slope floor towards the sump. Bedding shall be level. Vertical slope tolerance shall be $3/8$ in per 10 ft length toward the sump.

6.3 Vault Parts

- 6.3.1 Do not install parts cracked or otherwise damaged so that watertightness may be impaired.
- 6.3.2 Do not install parts cracked or otherwise damaged so that reinforcing is exposed.

6.4 Depth

The dimension from the vault top at the point of least depth to the pavement or ground above shall be as specified by Seattle City Light Work Order and/or construction drawings. Any deviation from this specification shall have the prior approval of the Seattle City Light Engineer.

6.5 Seal Mortar

Place approximate 2-inch mortar fillets to seal out water at joints between vault top, cover slab, risers, and frame.

6.6 Filling Spaces

Fill spaces through walls, tops, and slabs with dry pack mortar mixed with "Weldcrete" polyvinyl acetate bonding agent in accordance with the manufacturer's directions.

6.7 Ladder

Install a permanent ladder in the vault if the distance from the top of the grate to the vault floor exceeds 14 feet 5 inches. See Seattle City Light Drawing D-28304.

6.8 Wall Channels

- 6.8.1 Three lengths of galvanized "C" channel shall be embedded flush in each wall.
- 6.8.2 The end of the channel shall be 12 inches from the corner or duct window, whichever is closer.
- 6.8.3 The lowest channel length shall be 18 inches above the vault floor.
- 6.8.4 Channel spacing shall be 28-1/2 inches center-to-center starting from the bottom channel.

7. Duct Bank

- 7.1 Engineers shall specify the locations where the duct bank enters the vault on the work order.
- 7.2 Contractors/installers shall verify duct bank location before installation.
- 7.3 Duct bank knockout locations shall be marked by concrete impression on the inside wall for identification.
- 7.4 If possible, windows for duct runs on opposite walls shall be in alignment with each other so cable can be pulled through.
- 7.5 The edge of the ducts shall be from 3 inches (preferred) to no more than 6 inches from corner wall.
- 7.6 Duct runs that come in the same corner on adjacent walls shall be offset vertically so they don't interfere with each other.
- 7.7 Duct termination shall be recessed 6 inches with a 45° angled window edge.

8. Sump and Sump Discharge

- 8.1 Size and position the sump as necessary to leave room in the vault corners for pulling irons.
- 8.2 Trench sumps shall be minimum 12 inches deep with flush galvanized cover grate.
- 8.3 Locate sump at same end (below) as personnel hatch.
- 8.4 See NVH-60 for sump pump discharge pipe installation.

9. Grounding Electrode System

Install and test grounding electrodes per SCL 0461.10.

10. Backfill

Prior to backfilling, install all gaskets at top, bottom, and between walls and grout all seams and wall connections. Grout shall be non-shrink and reach 3000 psi minimum before backfilling.

Backfill with trench-type, controlled-density fill (CDF) that conforms to the City of Seattle Standard Specifications. Place backfill so that no voids are left under the reinforcing ribs or riser sections. The contractor/installer with the assistance of a Licensed Professional Engineer shall consult with the vault manufacturer to assure proper installation of the vault. Backfilling with some specified materials may require a multi-stage compaction processes to avoid damage to vault walls.

11. Vault Damage

Structurally damaged vaults shall be replaced or repaired. If the vault is to be repaired then a Washington State licensed professional engineer shall certify that the vault meets the original structural design parameters. For this Guideline, vaults with exposed rebar are considered to be damaged under any circumstances.

12. Proximity to Sewers

Vaults set within 5 feet 0 inches of, or over, sewers, will require replacement of the sewer pipe with ductile iron. The new ductile iron pipe must be placed beyond the vault at each end to a minimum of 3 feet 0 inches and/or into undisturbed soil to at least 2 feet 0 inches. Contractor shall do excavation, backfill, and restoration. Installation of the pipe will be made by the Seattle Public Utilities Department.

13. References

See Section 1 for code references.

14. Sources

Detter, Chris; SCL Standards Engineer and subject matter expert for NVH-80

Ng, Sharon; SCL Civil Engineer and subject matter expert for NVH-80

SCL Construction Guideline NCB-20; "Grounding Network System Transformer Vaults, Wet, Dry, or Spot – Copper Bus"

SCL Construction Guideline NCB-30; "Grounding Network System – Wet Vault, Non-Transformer, One or Two 48-Inch Bus Bars"

SCL Construction Guideline U2-11/NDK-10; "Installation of Nonmetallic Conduit, Concrete or CDF"

SCL Construction Guideline U2-12/NVH-60; "Sump Pump Pipe Installation, Vaults and Manholes"

SCL Construction Standard 0461.10; "Grounding Electrodes for Vaults and Handholes"

SCL Design Standard 9702.30; "Grounding and Bonding, Fundamentals and Detailed Requirements"

SCL Material Standard 7150.00; "Fluidized Thermal Backfill"

SCL Material Standard 7204.70; "Frames and Covers, 42-Inch Round, Iron"