

Precast Reinforced Concrete Transformer Pads



1. Scope

This standard covers the detailed requirements for precast reinforced concrete transformer pads.

This standard applies to the following Seattle City Light (SCL) stock numbers:

Stock No	Description
013721	Single phase transformer pad
013723	Three phase transformer pad (500–1500 kVA)
013724	Three phase transformer pad (2000–2500 kVA)

2. Application

Precast reinforced concrete transformer pads are used as a platform for transformers or switchgear.

If a precast or cast-in-place oil containment system is installed separately from the transformer pad, see SCL 0724.50 for installation details.

Due to their size, transformer pads will not be stocked in SCL inventory. Engineers and the Civil Crew Chief are required to order and specify delivery of these items.

3. General Requirements

This standard is to be used in conjunction with the latest revision of SCL 7203.21.

Standard Coordinator
Brett Hanson

Standards Engineering Supervisor
John Shipek

Division Director
Andrew Strong

4. Requirements, General

Pad grounding shall comply with SCL 7203.21.

Transformer pads shall be constructed according to the dimensions and details shown in Table 4.2 and figures 4.2a and 4.2b.

Table 4.2. Pad Dimensions

Stock No.	Dimensions, nominal (ft-in)			Blockout Dimensions, nominal (in)		Blockout placement from edge of pad (in)
	Width	Length	Height	Width	Length	
	W_p	L_p	H_p	W_b	L_b	Q
013721	4-0	4-8	0-6	22	14	8
013723	8-0	7-9	0-6	60	16	12
013724	8-0	10-0	0-8	60	24	12

Figure 4.2a. Transformer Pad

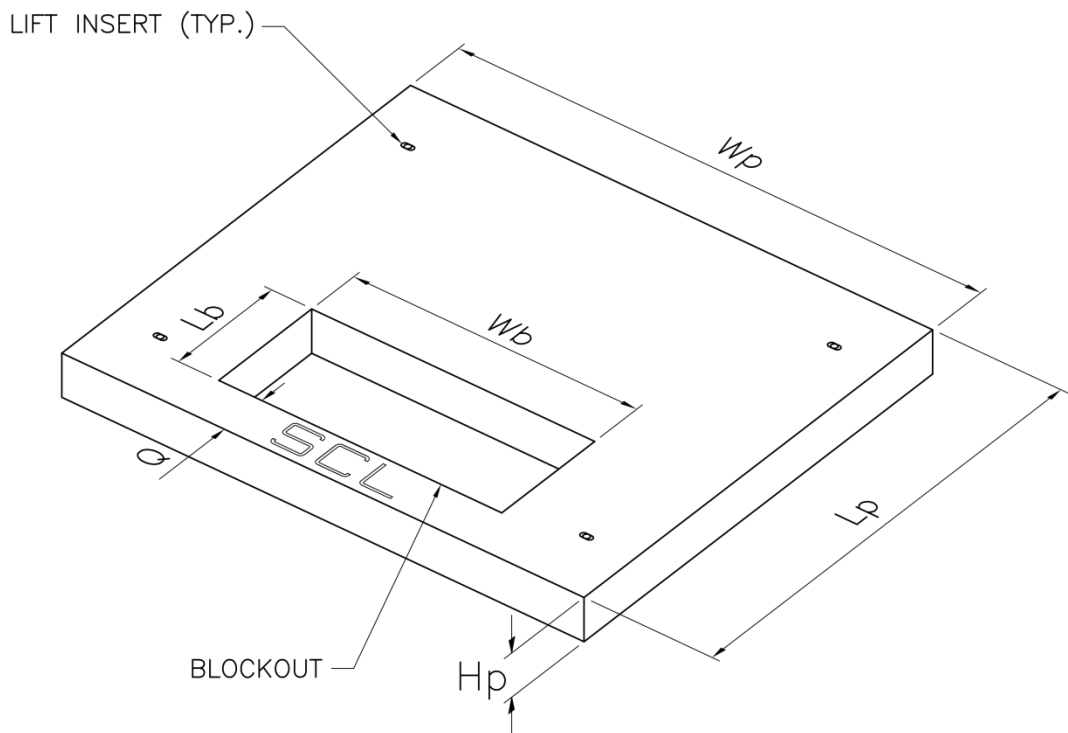
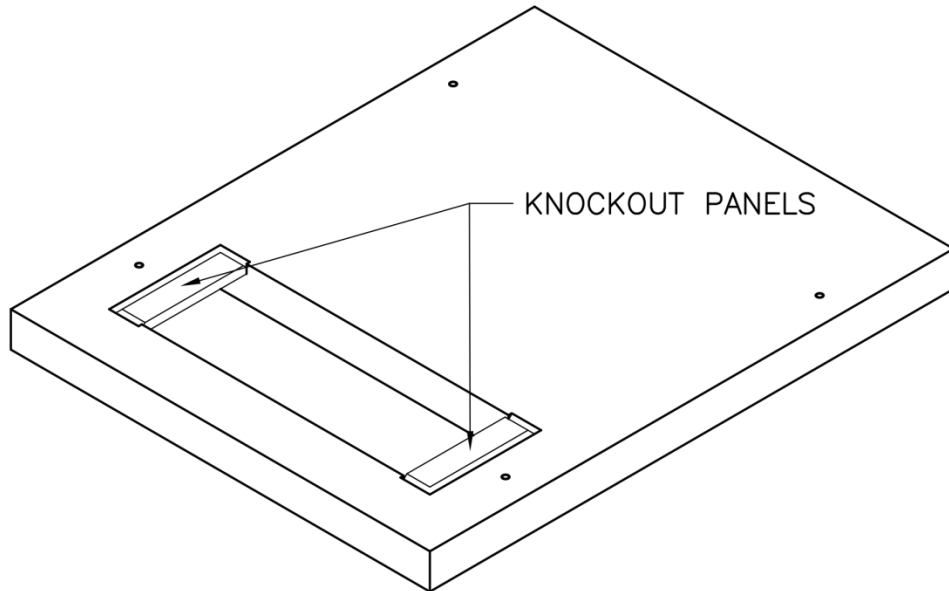

Figure 4.2b. Knockout Panel Detail



Lift inserts measuring 3/4-inch in diameter (nominal) shall be located at each corner on the top side of the pad.

Caps shall cover each lift insert.

For all transformer pads except for Stock No. 013274, the letters “SCL,” measuring 3-in high, shall be cast into the top side of the pad.

For Stock No. 013724, knockout panels measuring 6 in x 24 in shall be installed on each side of the blockout.

5. Issuance

Unit: EA

6. Approved Manufacturer

Stock No.	Description	Catalog No.
		Oldcastle/Utility Vault
013721	Single phase transformer pad	54-1422
013723	Three phase transformer pad (500–1500 kVA)	88-1660
013724	Three phase transformer pad (2000–2500 kVA)	77-810-2460

7. References

SCL Construction Standard 0724.50; “Customer Requirements for Padmount Transformer Services, Looped Radial System”

SCL Material Standard 7203.21; “Precast Reinforced Concrete Structure, General”

8. Sources

Ng, Sharon; SCL Civil Engineer and subject matter expert for 7203.76

Wang, Quan; SCL Standards Engineer, originator, and subject matter expert for 7203.76