

Clamps, Aluminum, Suspension



1. Scope

This standard covers the requirements for aluminum suspension clamps.

Aluminum suspension clamps consists of the body and keepers, a button-head pin, a cotter pin, socket eye and fastening hardware including U-bolts and nuts.

This standard applies to the following Seattle City Light (SCL) stock numbers:

Stock No.	Conductor Size Range (AWG/kcmil)
695115	4/0 – 397.5
695119	477 – 556.5
695137	795 – 954
695155	477 – 556.5 with armor rods
695167	795 with armor rods

2. Application

Aluminum suspension clamps are intended for use in construction of the pole top assemblies for three-phase armless angle poles supporting 397.5 kcmil ACSR to 954 kcmil ACSR primary conductors with ball-and-socket type suspension insulators. These clamps may be used with all aluminum, ACSR, or aluminum alloy conductors.

Socket eye fittings on deadend clamps may be used with Class 52-3 or 52-5 insulators as described in ANSI C-29.2B.

Ductile iron suspension clamps are used for ground wire applications with galvanized steel cable or static wires. Aluminum alloy and ductile iron clamps are not interchangeable.

3. Industry Standards

Aluminum suspension clamps shall meet the applicable requirements of the following industry standards:

ANSI/NEMA C29.2B; American National Standard for Insulators—Wet Process Porcelain and Toughened Glass—Transmission Suspension Type; 2013 Edition

ASTM A153; Standard Specification for Zinc Coating (Hot Dip) on Iron and Steel Hardware; 2005 Edition

4. Requirements

Aluminum suspension clamps and their keepers shall meet the following requirements:

- Be made of 356 T6 cast aluminum alloy or high-strength, heat-treated wrought aluminum alloy
- Be designed to meet the ultimate strengths shown in Table 4 and Figure 4.
- Have smooth surfaces and all edges rounded to prevent formation of corona or damage to the conductor.

The socket eye shall meet the requirements of ANSI/NEMA C29.2B as it applies to ball-and-socket gauge for Class 52-3 insulators.

Socket eyes shall have a nominal length of 2-1/6 inches. See Figure 4, bottom.

Fastening hardware and button-head pin shall be galvanized in accordance with ASTM A153.

The clamshell shall include two U-bolts with a nominal diameter of 1/2 inch.

The button-head pin shall be provided with cotter pins meeting the applicable requirements of SCL 5825.90.

Table 4. Aluminum Suspension Clamp Attributes

Stock No.	Conductor Size Range (AWG/kcmil)	Overall Diameter (in)		Ultimate Strength (lb)	Max. Take-Off Angle (degrees)	Dimensions, Nominal (in)			
		(min)	(max)			A	B	C	D
695115	4/0 – 397.5	0.40	0.80	15,000	30	7-1/2	2-1/2	1	5/8
695119	477 – 556.5	0.50	1.02	25,000	30	8	2-3/4	1-1/4	5/8
695137	795 – 954	1.00	1.45	25,000	22.5	9	3	1-9/16	5/8
695155	477 – 556.5 with armor rods	1.25	1.82	25,000	25	10	3-1/4	2	5/8
695167	795 with armor rods	1.75	2.25	25,000	20	10-1/2	4	2-3/8	5/8

Figure 4. Aluminum Suspension Clamp

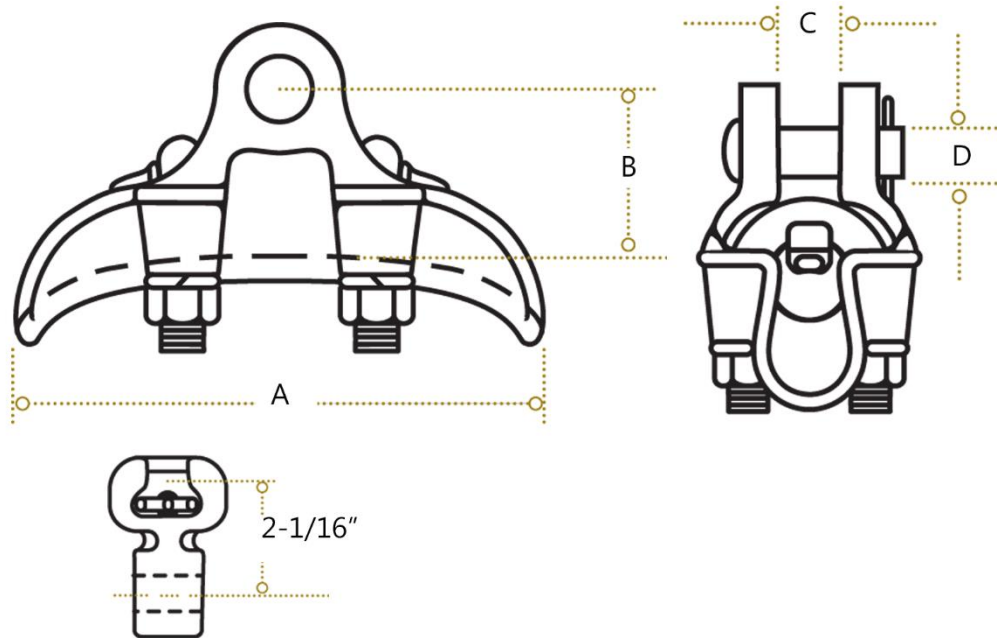

5. Marking

Each fitting shall be permanently and legibly marked in raised or stamped letters. Marking shall include but not be limited to the following information:

- - Manufacturer name or symbol
- - Manufacturer part number
- - Fitting ultimate strength

6. Packaging

Product shall be packaged to prevent damage during shipping, handling, and storage.

Standard package quantity shall not exceed 50 per box.

Standard package weight shall not exceed 50 pounds.

Individual packages shall be legibly marked with:

- Manufacturer name
- Manufacturer catalog number
- Product description
- SCL stock number

Shipping containers shall be legibly marked with:

- SCL purchase order number
- SCL stock number

7. Issuance

Stock Unit: EA

8. Approved Manufacturers

Stock No.	Hubbell Power Systems/Anderson	MacLean Power Systems
695115	HAS-85S	LS-1S
695119	HAS-104S	LS-2S
695137	HAS-147S	LS-6S
695155	HAS-182S	LS-8S
695167	HAS-227S	ASC-10S

9. References

SCL Material Standard 5825.90; “Cotter Pin, Humpback, Stainless Steel”

10. Sources

ANSI H35.1/H35.1(M); American National Standard Alloy and Temper Designation Systems for Aluminum; 2013 Edition

ASTM B179; Standard Specification for Aluminum Alloys in Ingot and Molten Forms for Castings from All Casting Processes; 2014 Edition

ASTM B308/B308M; Standard Specification for Aluminum-Alloy 6061-T6 Standard Structural Profiles; 2010 Edition

ASTM B686/B686M; Standard Specification for Aluminum Alloy Castings, High-Strength; 2014 Edition

SCL Material Standard 6951.1 (canceled); “Clamps, Aluminum Suspension”

Wang, Quan; SCL Standards Engineer and originator of 6940.30
(quan.wang@seattle.gov)

www.hubbellpowersystems.com

www.macleancleanpower.com