

WELD-IN ADAPTER RING AND GASKET FOR 13 kV PATR 1701 TERMINATOR REPLACEMENT

Also used to convert 26kV Network Transformers when welded onto terminal chamber and using bushing Stock Number 686387.

Adapter Plate
Stock No.: 686250

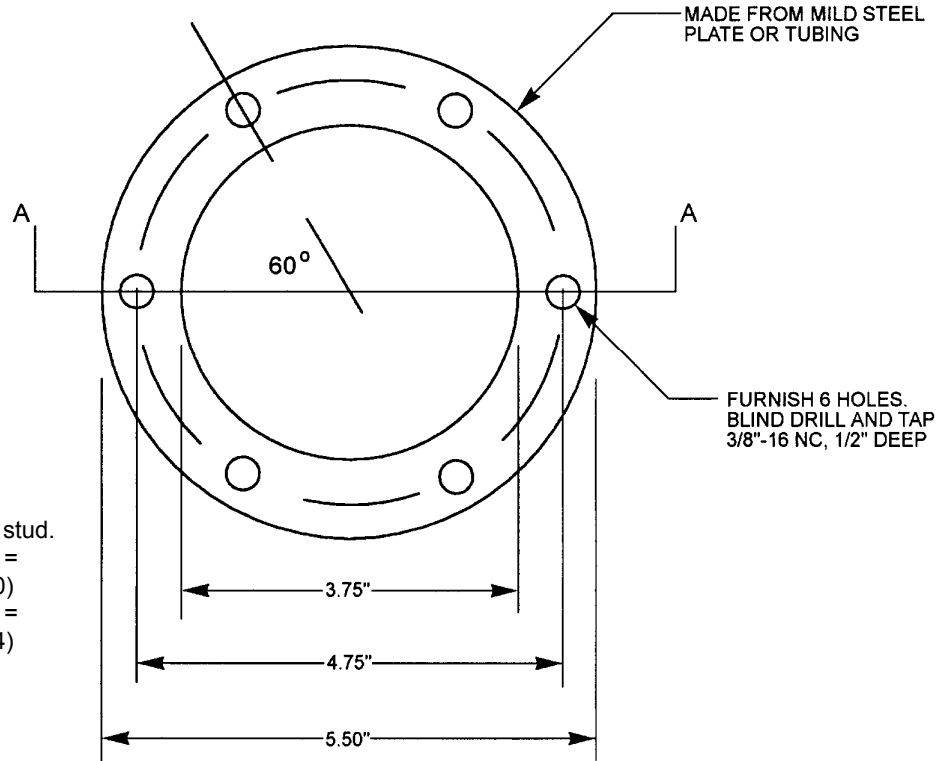

Install 6 each:
 3/8" - 16NC x "L" bronze stud.
 For Stock No. 687009, L = 2-3/8" (Stock No. 786600)
 For Stock No. 686387, L = 1-1/2" (Stock No. 012944)
 Seat studs lightly.
 Locktite in place.
 Protect studs with Caplug® or equal.

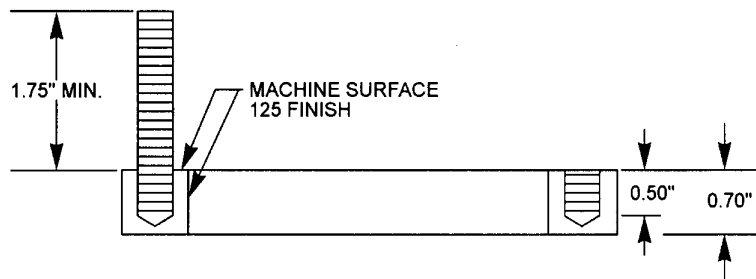

Application: For conversion of wiped lead pothead to straight 600 ampere bushing on 13 kV network transformers and other apparatus. See Stock Catalog page 70-47 for gasket and bushing Stock Numbers.

standards coordinator

Quan Wang
Quan Wang

standards manager

John Shipek
John Shipek

unit director

Pam S. Johnson
Pam S. Johnson

MATERIAL STANDARD

Weld-In Adapter Ring and Gasket for 13 kV PATR 1701 Terminator Replacement

standard number: **6862.5**
superseding: September 10, 2001
effective date: November 13, 2009
page: 2 of 2

Gasket
Stock No.: 686386

For use with 686250 adapter plate shown on page 1.

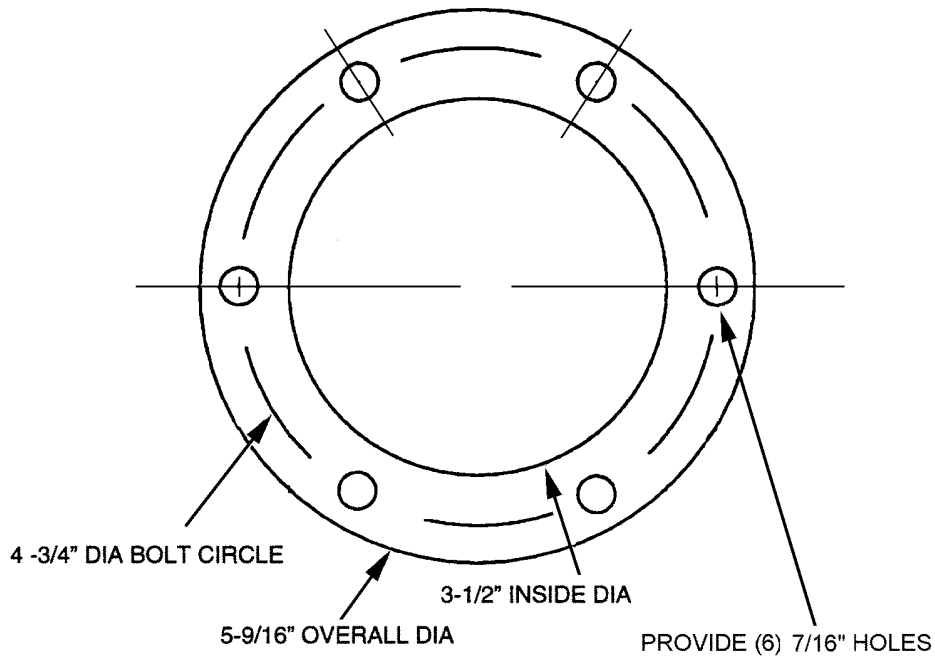

Material: Cork & Synthetic (Buna N) Rubber Composition: 3/16", C.L. Stock no.: 727687

Material Standard: 7276.9

Stock Unit: EA

Application: For both the adapter plate and gasket. For conversion of PATR 1701 pothead to 600 ampere apparatus bushing on 13 kV network transformers and other apparatus. See Stock Catalog page 70-47 for more information.