

Access Door, Steel, Chief Seattle Streetlight Base



1. Scope

This material standard covers the fabrication requirements for Chief Seattle base access doors.

This material standard applies to Seattle City Light stock number 014373.

2. Application

Railroad green steel doors are used to replace missing access doors from cast aluminum or bronze Chief Seattle streetlight bases. These doors fit all styles of Chief Seattle streetlight bases.

Screw holes will be field drilled to match hole pattern on the existing base.

This standard does not apply to cast aluminum or bronze access doors that accompany the complete Chief Seattle streetlight base assembly.

3. Requirements

Access doors shall have the following attributes:

- Made of 14-gauge steel
- Nominal dimensions of 12-3/8 in wide by 10-1/4 in high
- Rolled with 38-in radius as shown in Figure 3a and 3b
- Surfaces properly prepared and painted Railroad Green

Access door shall have two flat bars welded on the convex side as shown in Figure 3c.

- The top flat bar shall be 1 in by 8 in by 1/8 in
- The bottom flat bar shall be 1 in by 9 in by 1/8 in
- Flat bars shall be welded together with 3/8-in offset as shown in Figure 3c

Figure 3a. Access Door Curvature and Dimensions

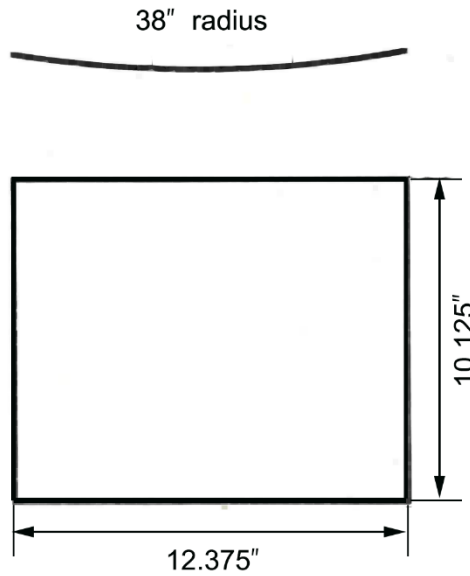

Figure 3b. Access Door with Flat Bar

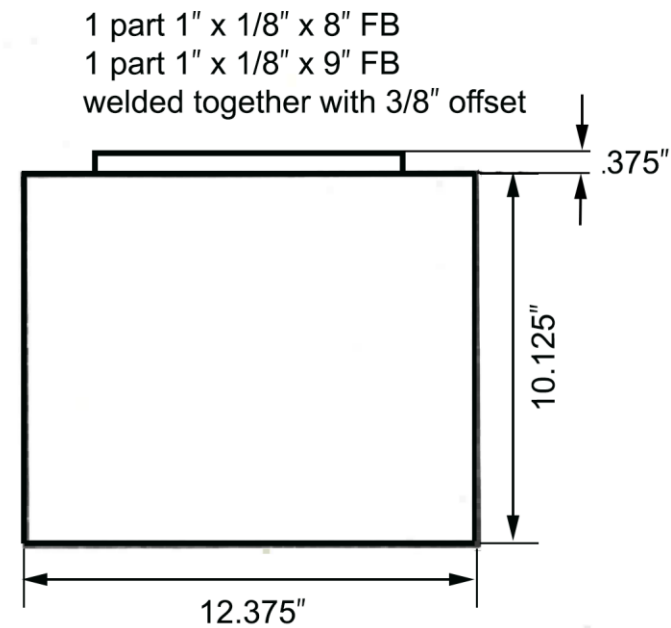
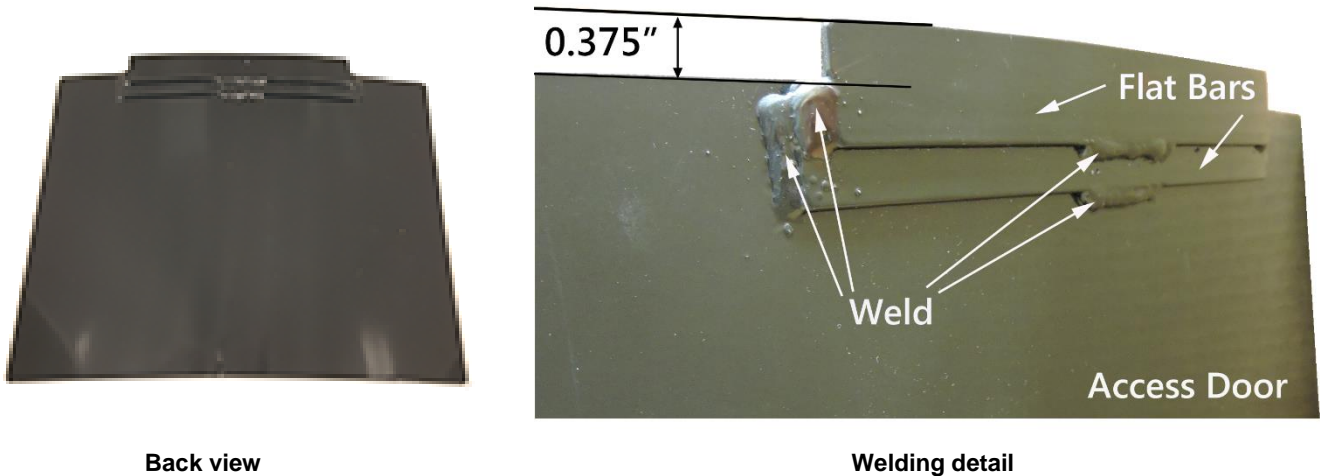

Figure 3c. Flat Bar Welding Detail



4. Packaging

Access doors shall be packaged to prevent damage during shipping, handling, and inside storage.

Product may be placed in containers or on pallets, as determined by storage location.

Each package shall be legibly marked with the following information:

- Manufacturer identification
- Product description
- Seattle City Light stock number
- Quantity contained

5. Issuance

EA

6. Approved Manufacturer

This stock item will be fabricated and painted by Seattle City Light shops.

7. Sources

Cody, Rhonda; SCL Material Supplier and subject matter expert for 5780.51
(rhonda.cody@seattle.gov)

SCL Material Standard 5680.51; Access Door, Steel, Chief Seattle Streetlight Base"
(canceled/renumbered)

SCL Material Standard 5780.33; "Cast Aluminum Streetlight Base and Collar Assembly"

SCL Material Standard 5780.44; "Cast Bronze Streetlight Base and Collar Assemblies"

Wang, Quan; SCL Standards Engineer and originator of 5780.51
(quan.wang@seattle.gov)