Single-Phase Overhead Jumpers, Unfused

1. Scope

This standard covers the information necessary to install single-phase jumpers on the 26 kV primary distribution system. Requirements for jumper size and hardware, and installation instructions to connect the jumpers between conductors, are included.

2. Application

This standard provides direction to Seattle City Light (SCL) engineers, crews, and contractors for the installation of jumpers on 26 kV distribution primary (#4 AWG copper, 397.5 kcmil ACSR, and 954 kcmil ACSR) and neutral (4/0 AWG Al and #4 AWG copper) conductors.

For installing fused jumpers, refer to SCL 0100.25.

3. Requirements

Jumpers connect two conductors on the same feeder that have been separated, typically at double deadends, large angles, corners, and laterals on different gains.

Jumper conductors at structures shall not limit the ampacity of the main line and will use a minimum conductor size of the smaller of the two conductors being jumpered.

Long jumpers or jumpers with a large radius shall use insulators to maintain clearances. For the SCL 26 kV system, the jumpers shall maintain a minimum 24-inch clearance from the center of the pole. The jumper shall also maintain a minimum of 7.3 inches from another phase of the same circuit or 12.9 inches from another phase of a different circuit.

When connecting dissimilar metals, use the proper wedge connector or stirrup.

Use Table 3 to determine the proper jumper to use and the jumper shall be constructed as shown in the referenced figures. Use multi-gain compatible units (CUs) when constructing in-line double deadends.



Table 3. Single-Phase Jumper Application

Phase	Type	Gain	Angle	Figures
3 to 1	Deadend to Deadend	1 or 2	0-60	3a, 3b
3 to 1	Deadend to Deadend	1	60-180	3c, 3d
1 to 1	Deadend to Deadend	1	0-100	3e, 3f
1 to 1	Deadend to Deadend	1	0-100	3g, 3h
1 to 1	Deadend to Deadend	2	0-60	3i, 3j
1 to 1	Tangent to Deadend	2	0-180	3k, 3l
1 to 1	Deadend to Deadend	2	60-180	3m, 3n
1 to 1	Tangent to Tangent	2	All	3o, 3p
1 to 1	Tangent to Tangent	1	All	3q

Figure 3a. Single-Phase Double Deadend 0°–60° Crossarm Jumper, Top View

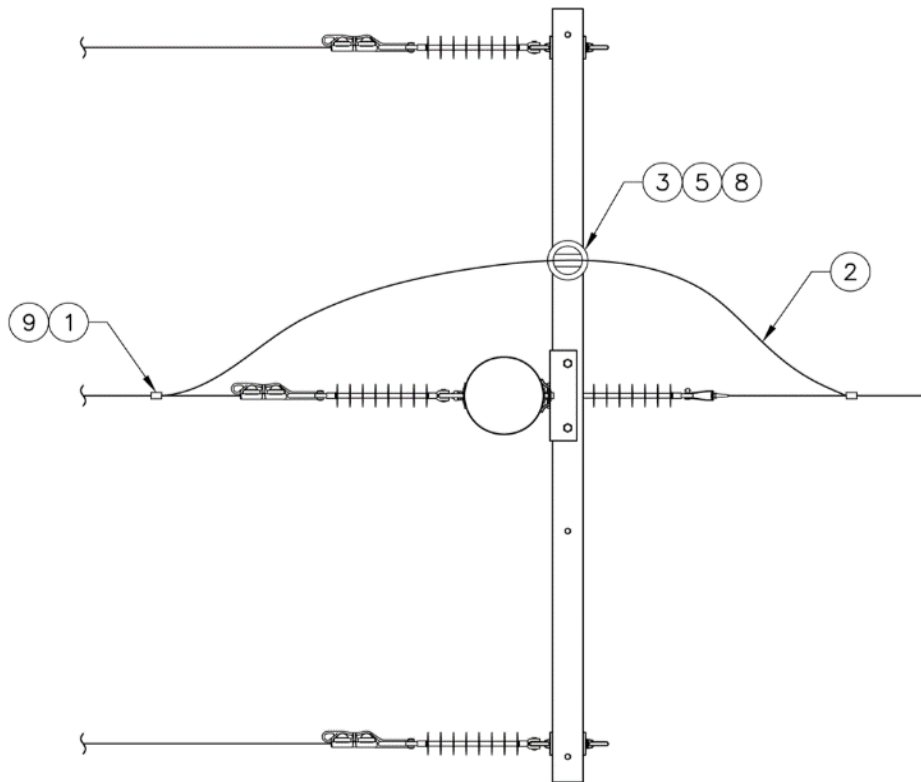

Figure 3b. Single-Phase Double Deadend 0°–60° Crossarm Jumper, Side View

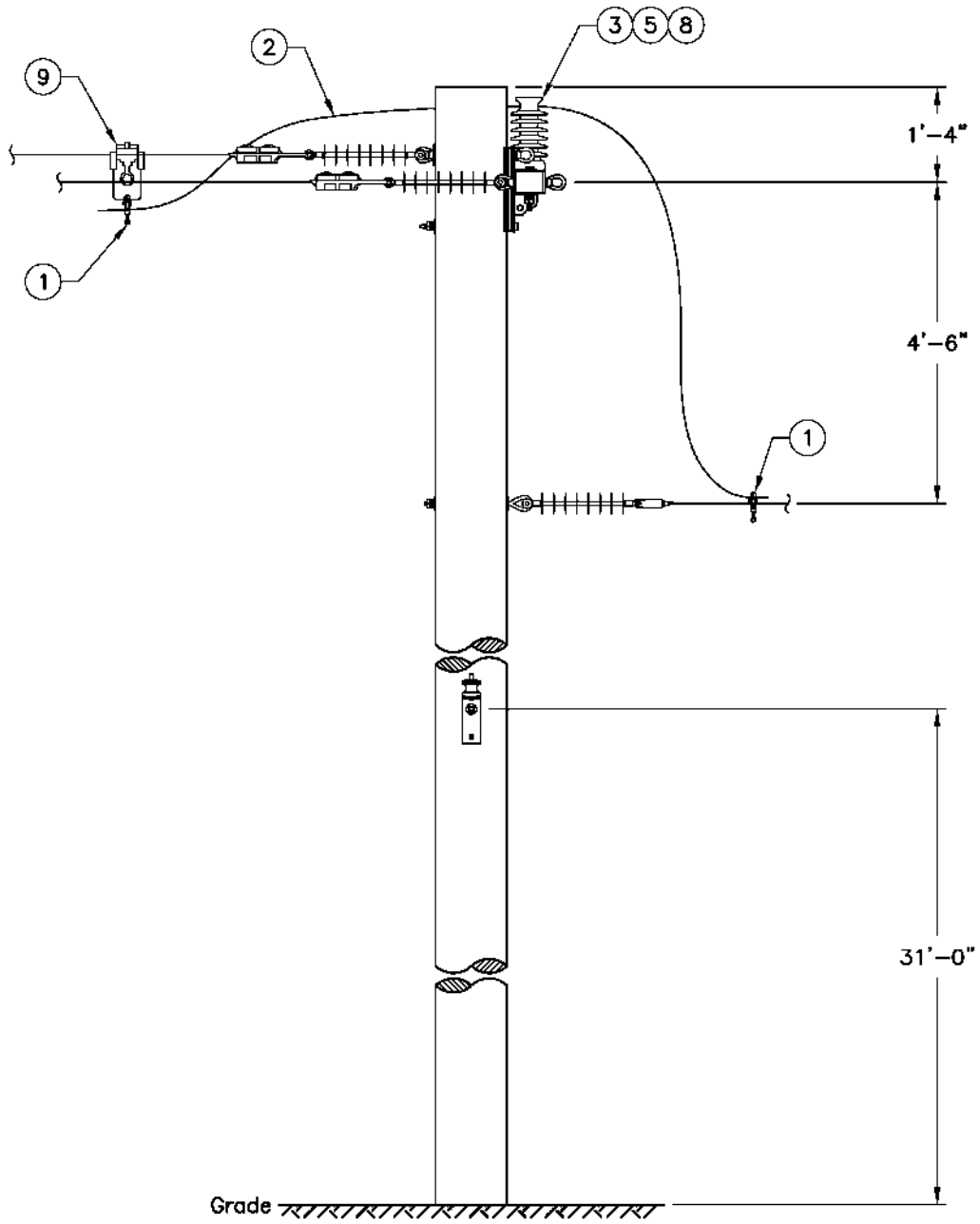

Figure 3c. Single-Phase Double Deadend 60°–180° Crossarm Jumper, Top View

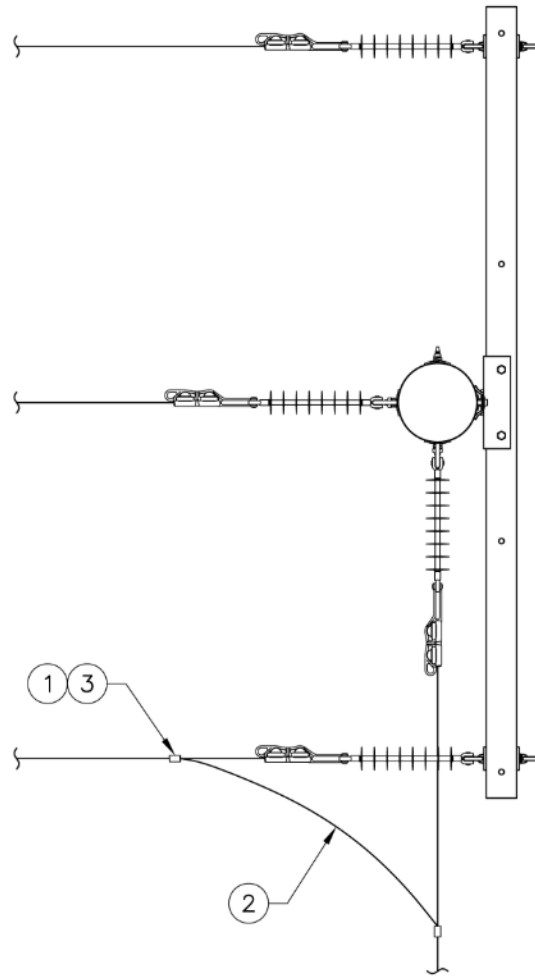

Figure 3d. Single-Phase Double Deadend 60°–180° Crossarm Jumper, Side View

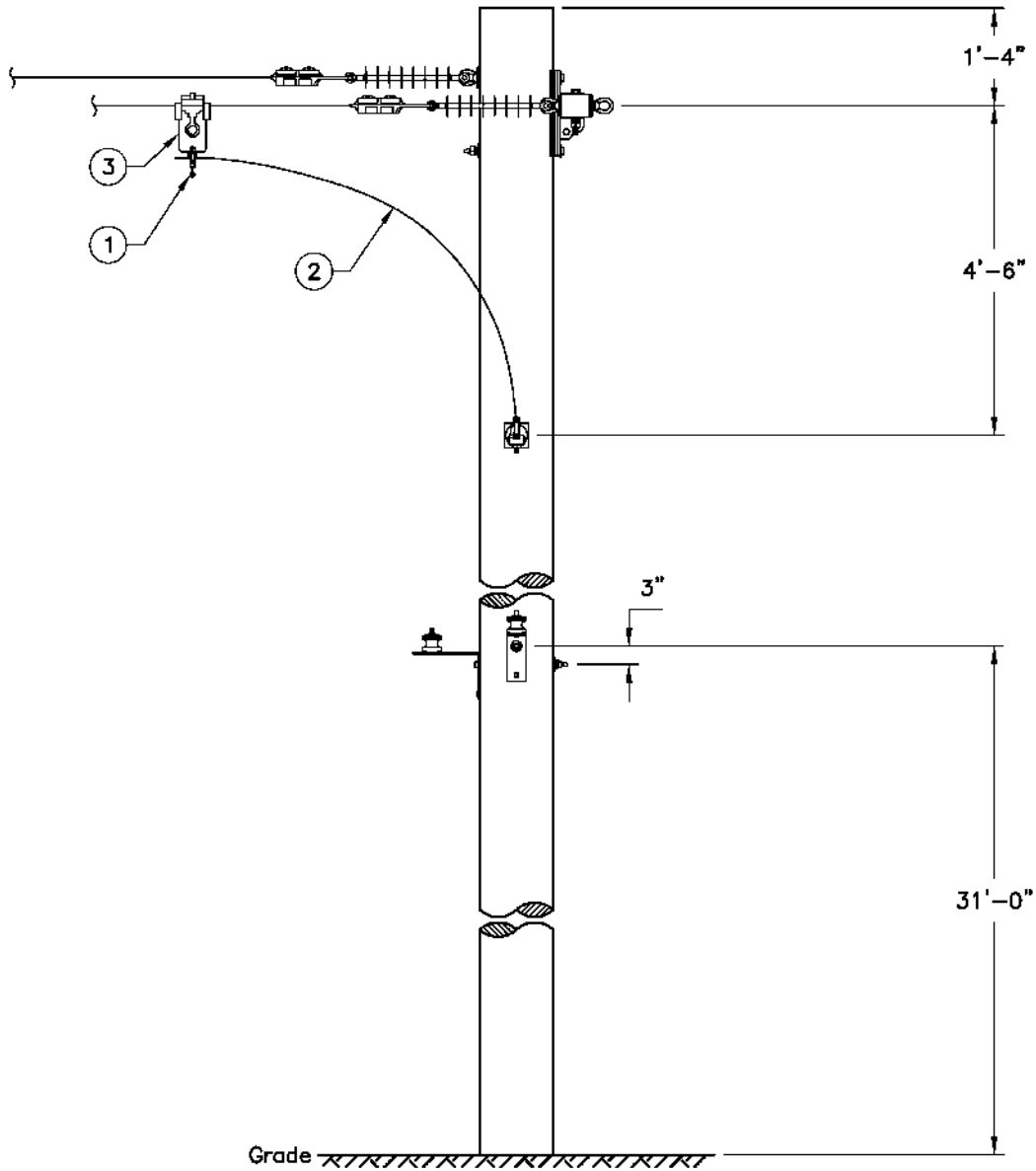

Figure 3e. Single-Phase Single-Gain Double Deadend 0°–100° Head Pin Jumper, Top View

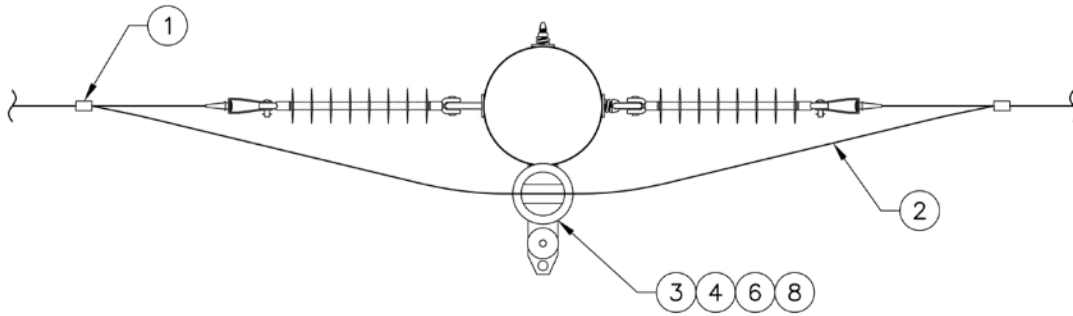

Figure 3f. Single-Phase Single-Gain Double Deadend 0°-100° Head Pin Jumper, Side View

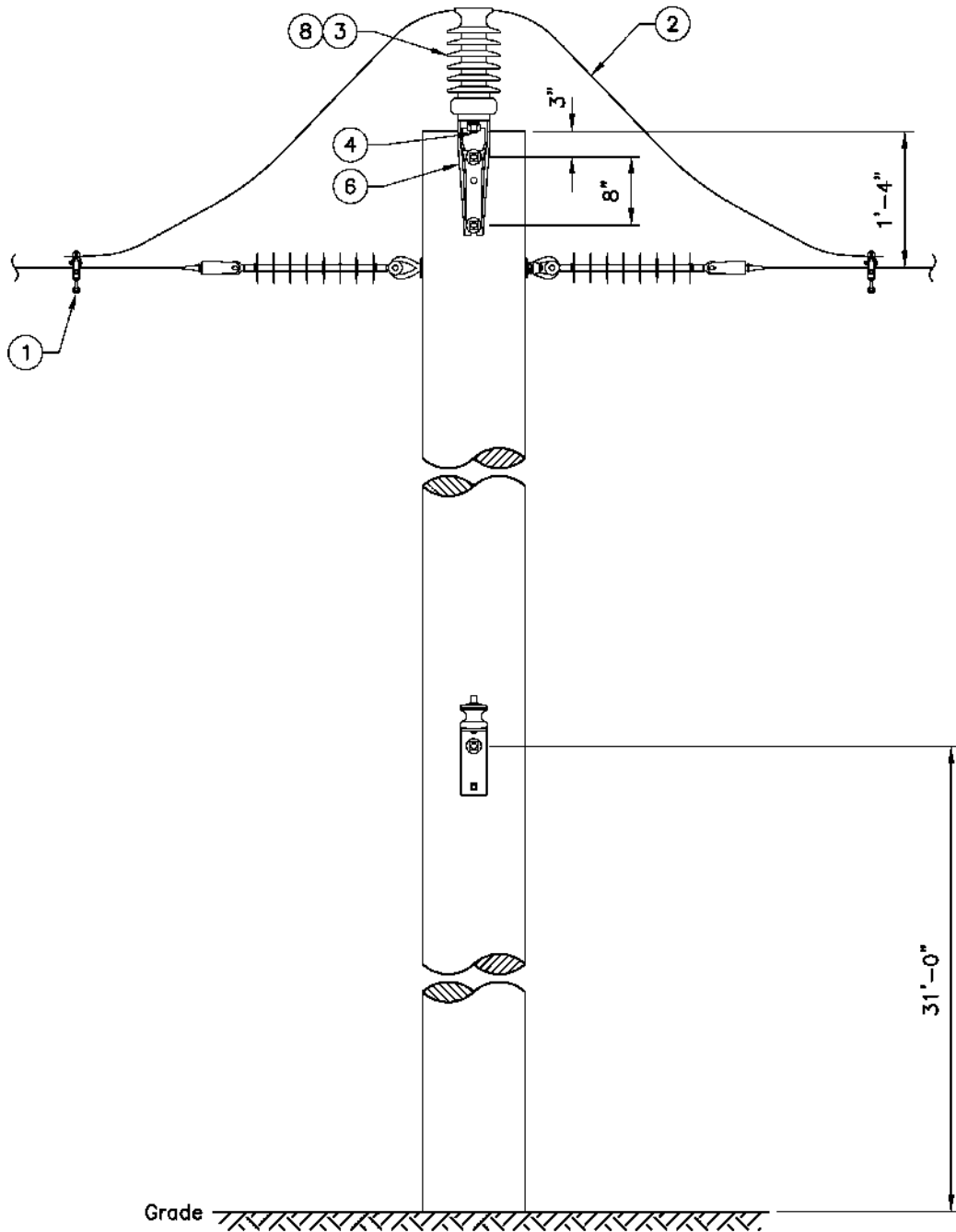

Figure 3g. Single-Phase Single-Gain Double Deadend 0°–100° Side Mount Jumper, Top View

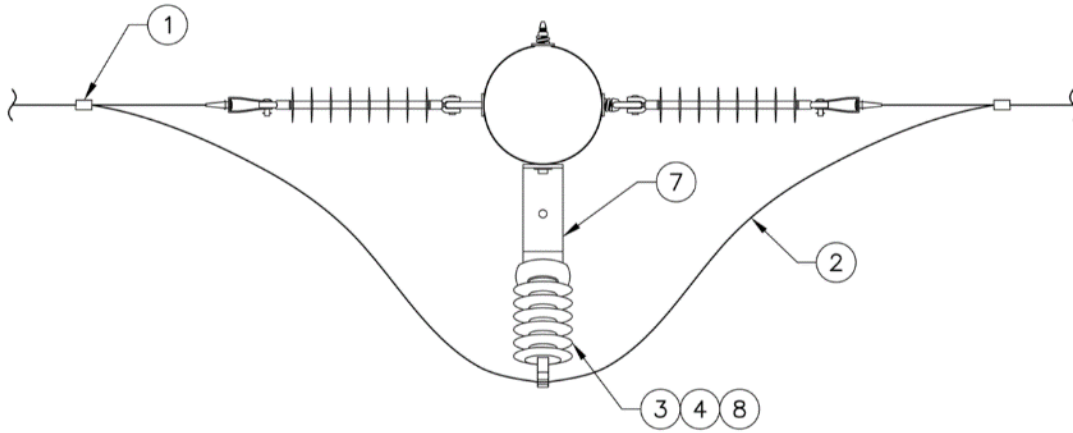

Figure 3h. Single-Phase Single-Gain Double Deadend 0°-100° Side Mount Jumper, Side View

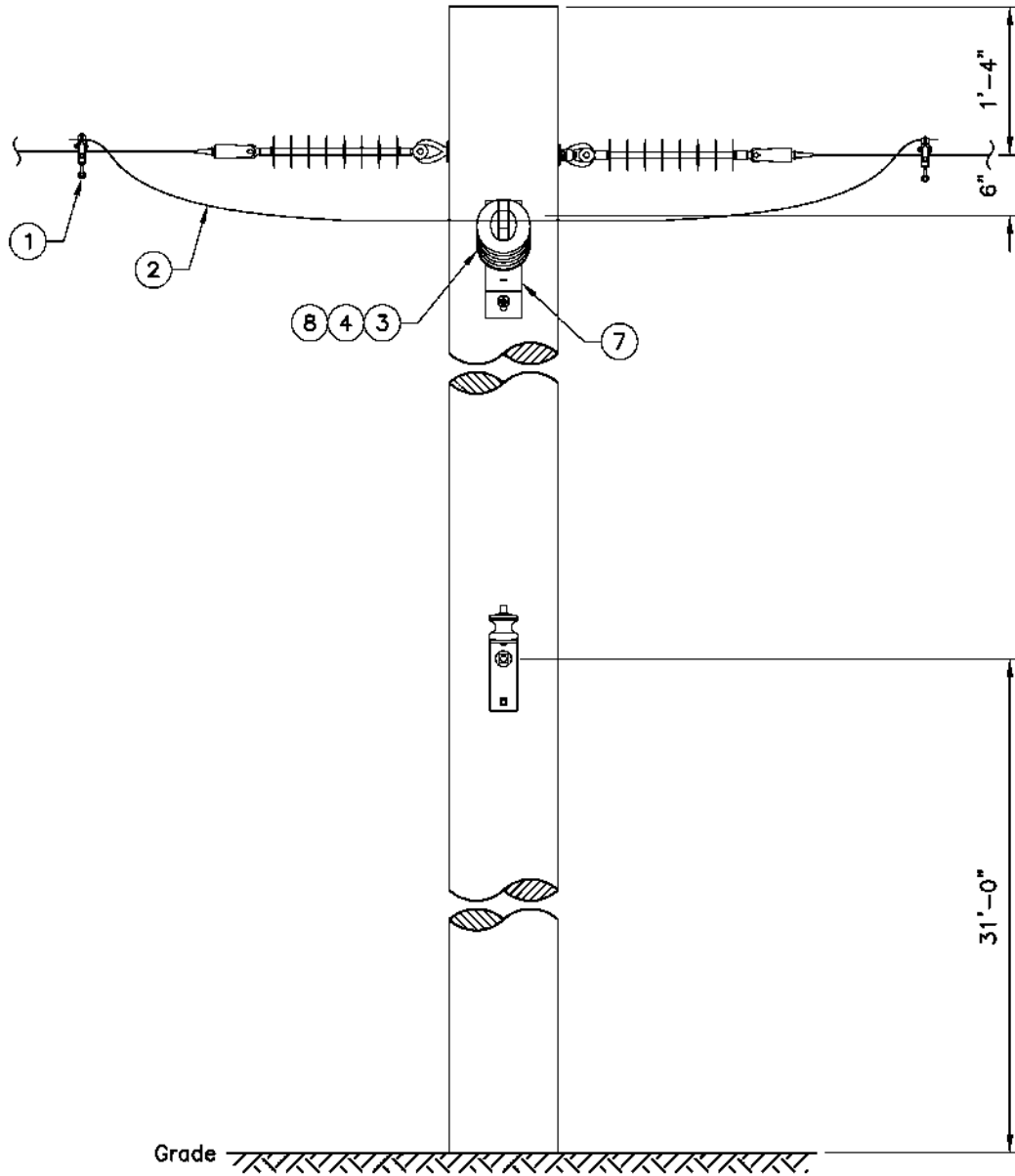

Figure 3i. Single-Phase Multi-Gain 0°-100° Deadend to Deadend Side Mount Jumper, Top View

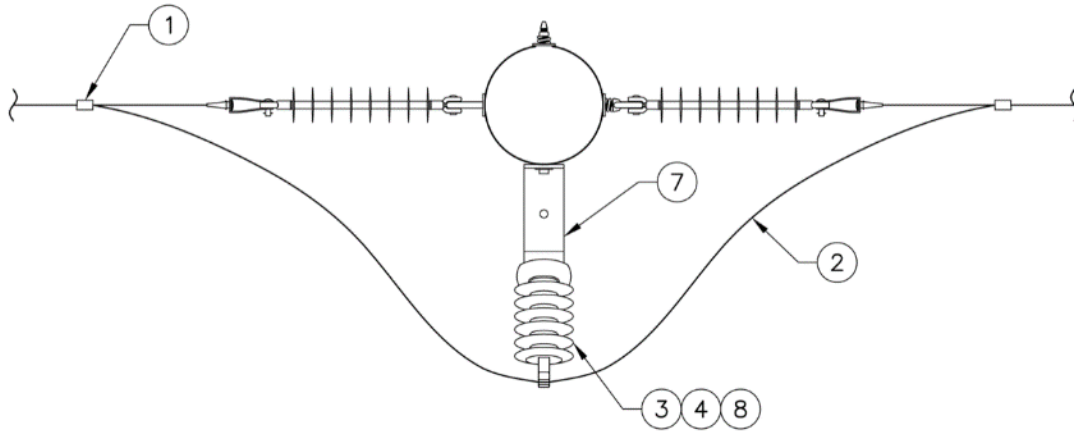

Figure 3j. Single-Phase Multi-Gain 0°-100° Deadend to Deadend Side Mount Jumper, Side View

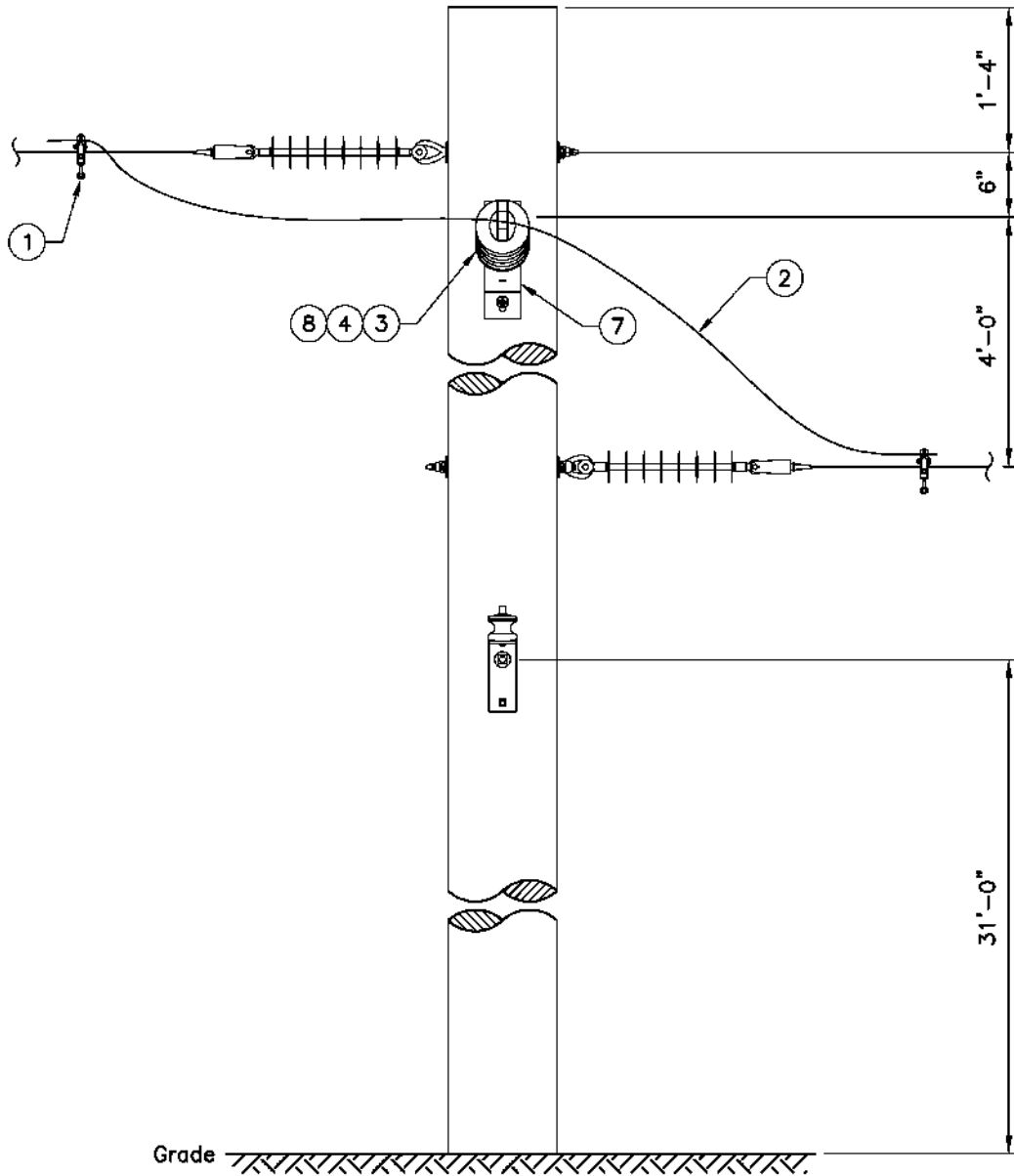

Figure 3k. Single-Phase Multi-Gain Tangent to Deadend Jumper, Top View

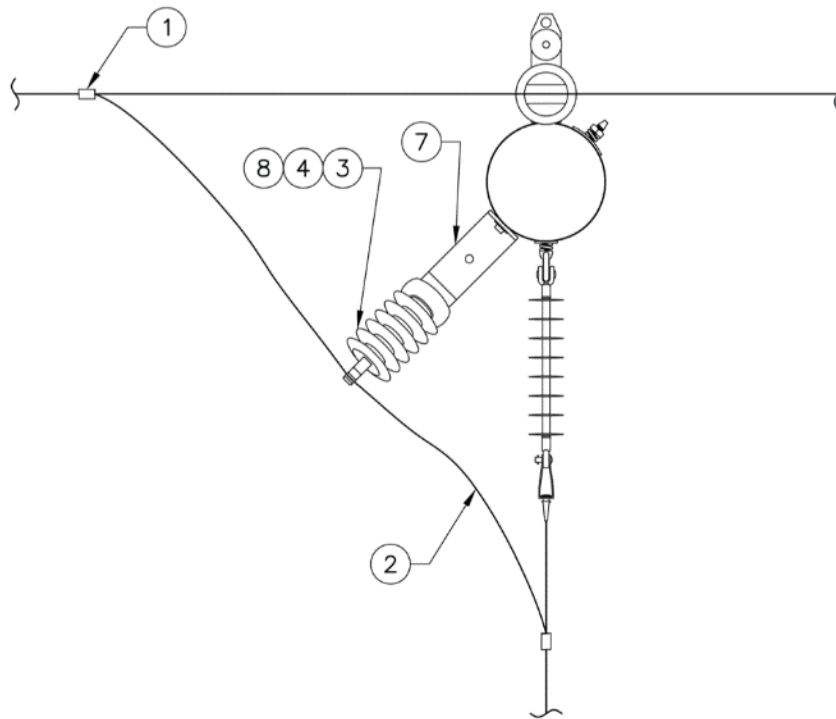

Figure 3I. Single-Phase Multi-Gain Tangent to Deadend Jumper, Side View

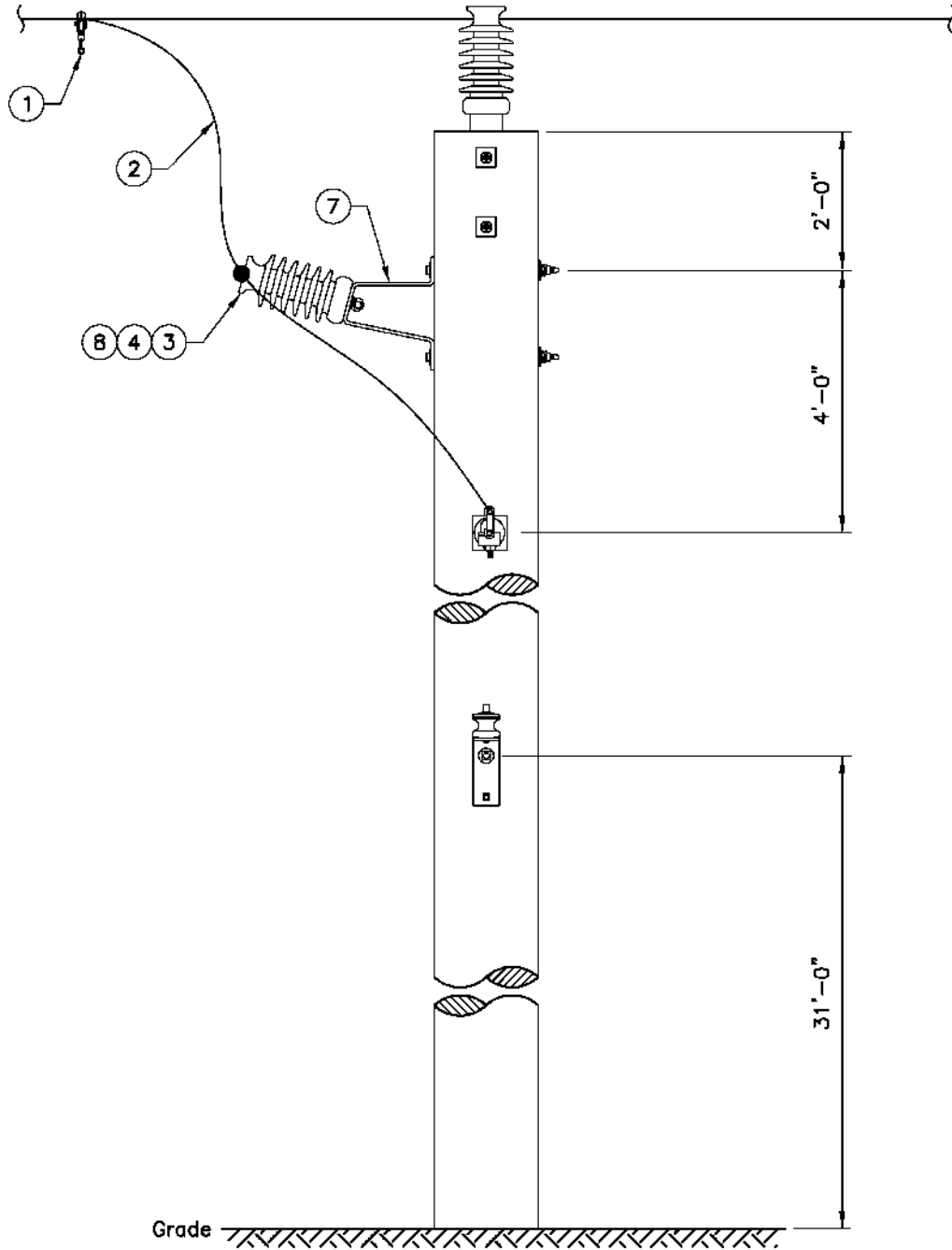

Figure 3m. Single-Phase Multi-Gain 100°-180° Jumper, Top View

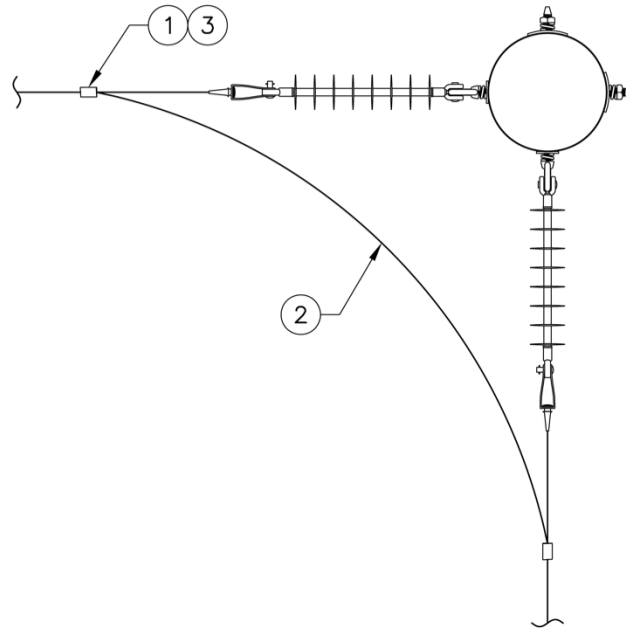

Figure 3n. Single-Phase Multi-Gain 100°-180° Jumper, Side View

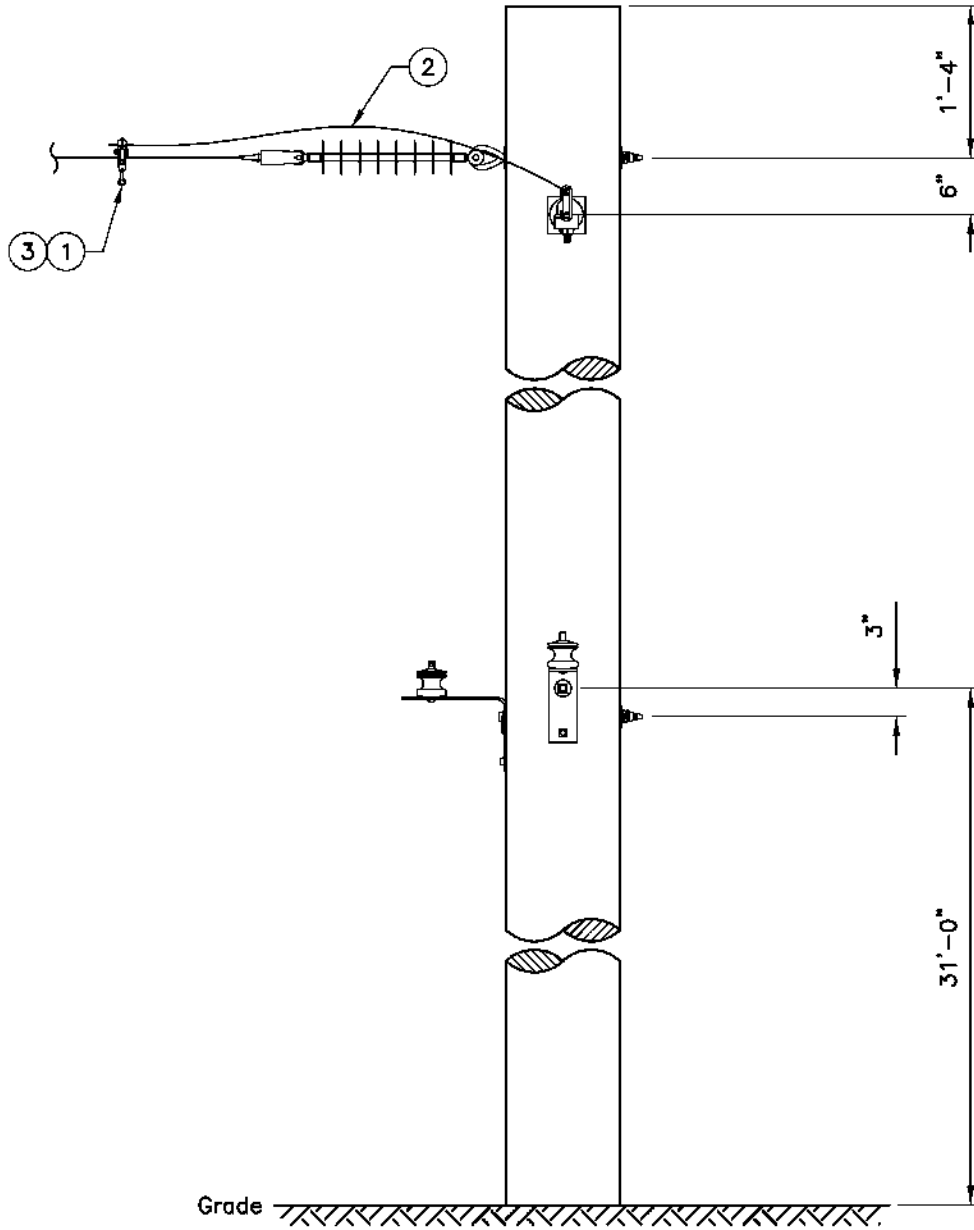

Figure 3o. Single-Phase Multi-Gain Tangent to Tangent Jumper, Top View

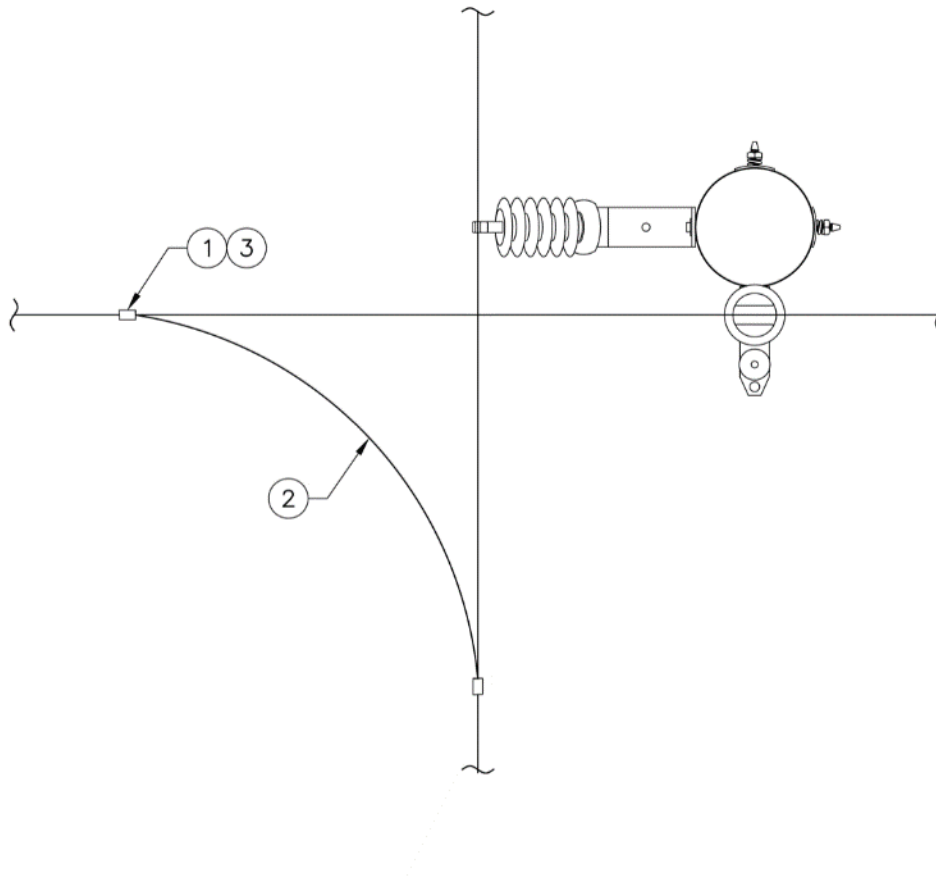

Figure 3p. Single-Phase Multi-Gain Tangent to Tangent Jumper, Side View

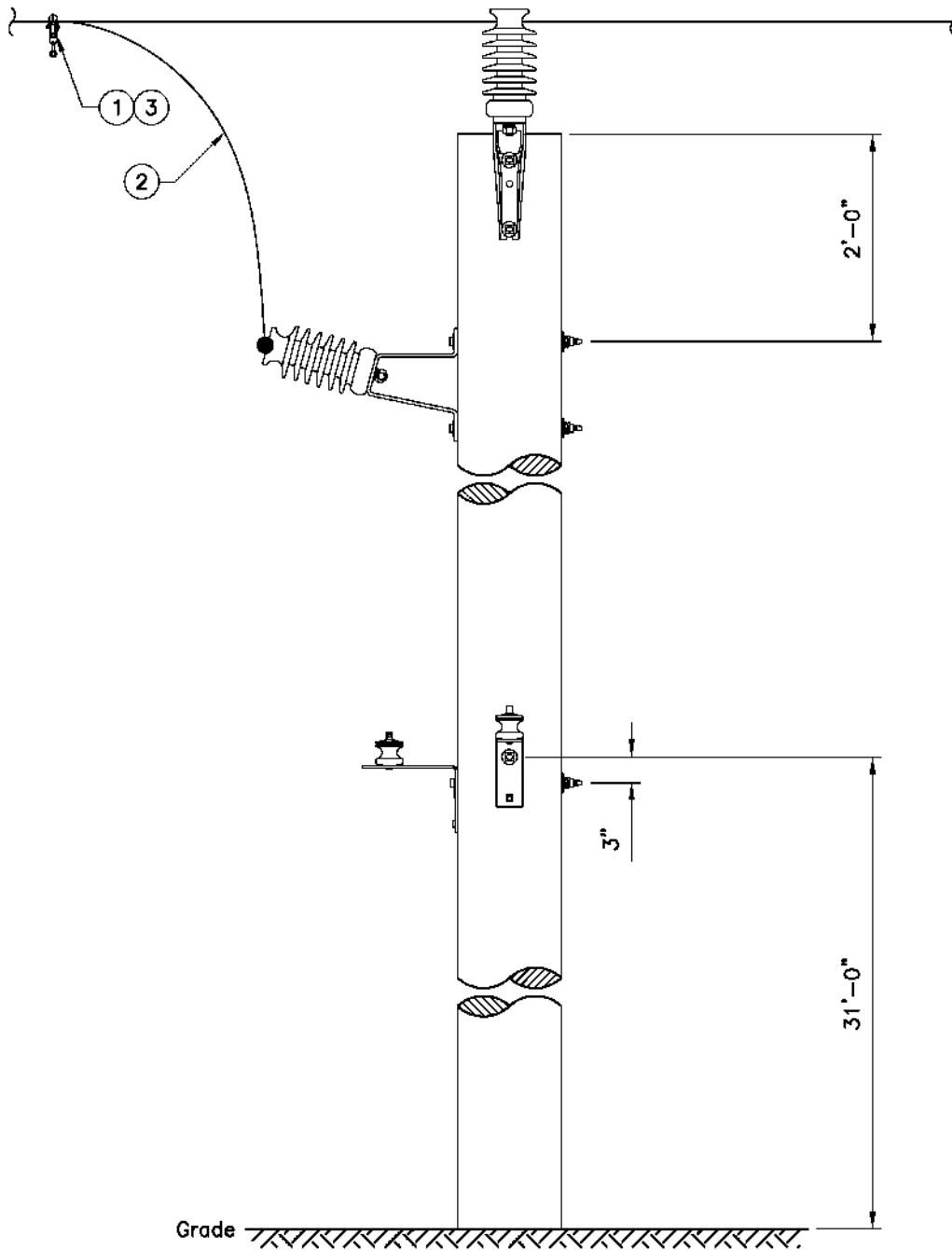
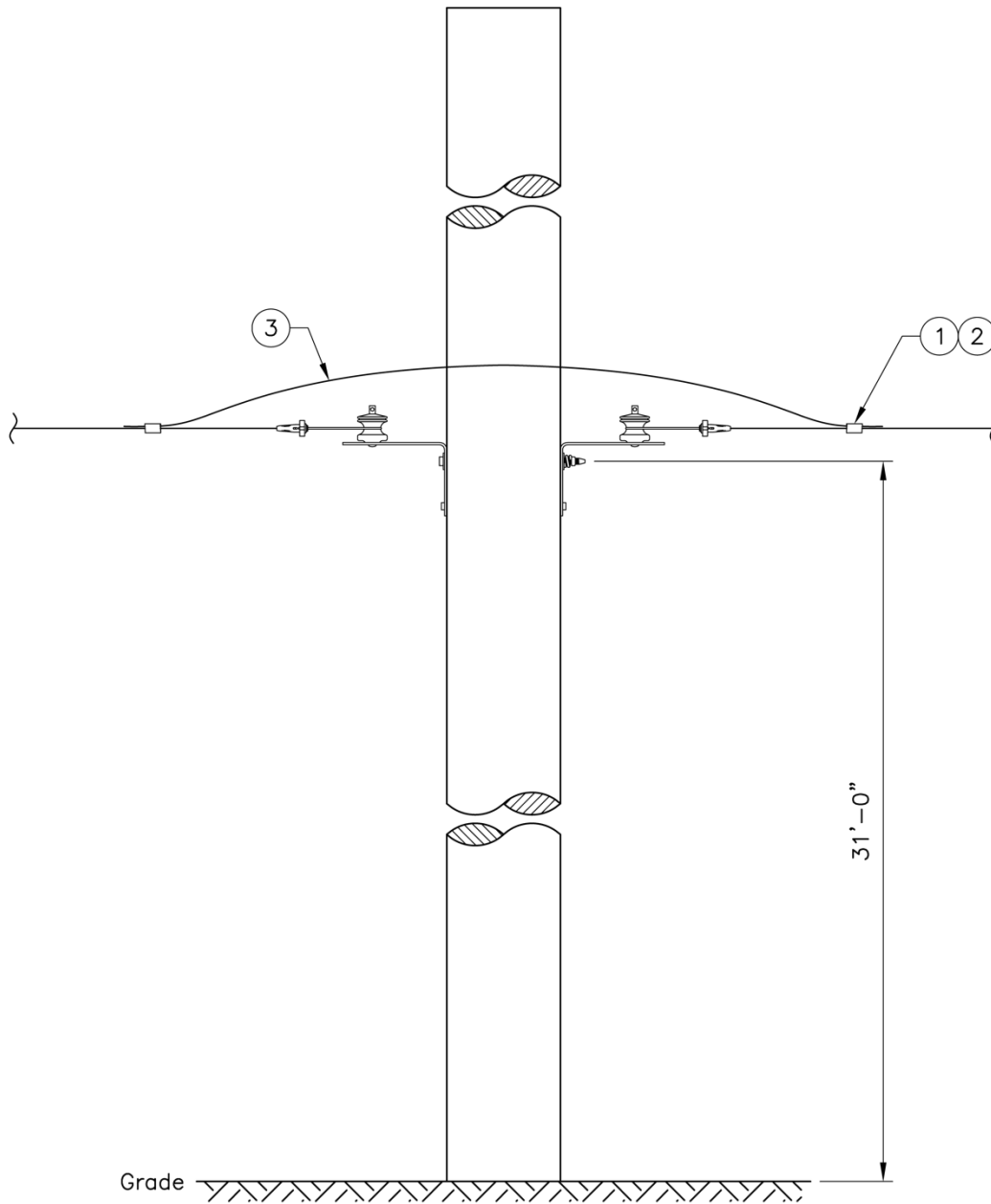

Figure 3q. Neutral Jumper, Side View



4. Construction Notes

Return any unused materials to the warehouse.

5. Material Lists

Table 5a. Single-Phase Jumpers with No LPs

Fig	Compatible Unit	ID	Quantity		
3c, 3m, 3o	Single-phase DDE 60°-180°, multi-gain 100°-180°, multi-gain T-T	JMPR1#4-1#4			
3c	Single-phase DDE 60°-180°	JMPR397-1#4			
3c	Single-phase DDE 60°-180°	JMPR954-1#4			
#	Material Description	ID			
1	Clamp, hot line tap, #8 - 2/0	580725	2	2	2
2	Wire, solid bare, Cu, SD, #4 AWG (ft)	610208	20	20	20
3	Stirrup, bolted, 397.5–954 kcmil ACSR	580678	1	1	–

Table 5b. Single-Phase Jumpers with 1 LPI

Fig	Compatible Unit	ID	Quantity				
3i, 3k, 3g	Multi-gain 0°-100° DE-DE side mount, multi-gain T-DE	JMPR1#4-1#4BUCK					
3e	Single-gain DDE 0°-100° head pin	JMPR1#4-1#4DDE					
3a	Three-phase to single-phase DDE 0°-60°	JMPR3#4-1#4BUCK					
3a	Three-phase to single-phase DDE 0°-60°	JMPR397-1#4BUCK					
3a	Three-phase to single-phase DDE 0°-60°	JMPR954-1#4BUCK					
#	Material Description	ID					
1	Clamp, hot line tap, #8 - 2/0	580725	2	2	2	2	2
2	Wire, solid bare Cu, SD, #4 AWG (ft)	610208	20	20	20	20	20
3	Insulator, post top, 34.5 kV (tie-top)	690157	1	1	1	1	1
4	Stud, short, 3/4" x 1-3/4"	696826	–	–	–	1	1
5	Stud, long, 3/4" x 7-1/2"	696828	1	1	1	–	–
6	Bracket, pole top	563253	–	–	–	1	–
7	Bracket, side mount	580510	–	–	–	–	1
8	Wire, solid, bare, #6 Cu SD (ft)	610210	1	1	1	1	1
9	Stirrup, bolted, 397.5–954 kcmil ACSR	580678	1	1	–	–	–

Table 5c. Neutral Jumper

Fig	Compatible Unit	ID	Quantity		
3q	Neutral jumper	JMPR4/0N-#4N			
3q	Neutral jumper	JMPR#4N-#4N			
3q	Neutral jumper	JMPR4/0N-4/0N			
#	Material Description	ID			
1	Split bolt tap, #4 AWG	668864	-	2	1
2	Wedge connector, 4/0-4/0	013611	2	-	-
2	Wedge connector, Cu, #4 - 4/0	013618	-	-	1
3	Wire, solid Cu, MHD, #4 AWG (ft)	611392	-	10	10
3	Wire, str Al, 4/0 (ft)	600113	10	-	-

6. References

SCL Construction Standard 0100.25; "Fused Overhead Jumpers"

7. Sources

Hall, Alan; SCL Senior Electrical Engineer and subject matter expert for 0100.21
 (alan.hall@seattle.gov)

Lu, Curtis; SCL Standards Engineer and originator of 0100.21 (curtis.lu@seattle.gov)