

Composite Utility Poles, Modular



1. Scope

This standard covers the requirements for modular composite utility poles and their accessories.

Composite utility poles are sometimes referred to as fiberglass or fiber-reinforced-polymer (FRP) poles.

This standard applies to the following Seattle City Light (SCL) stock numbers:

Stock No.	Description
013313	30 ft, class H1 assembly
013172	40 ft, class H2 assembly
013173	50 ft, class 1 assembly
013174	55 ft, class 1 assembly
014618	60 ft, class H1 assembly
013175	Jacking lug
013177	Climbing step hole plug
013524	Pole module joining hardware kit
013745	Climbing step with fall arrest
014672	Jacking bar assembly kit
014677	13/16" hole plug (crossarms)
014678	11/16" hole plug (head pins and secondary insulators)

Standard Coordinator
Ponet Neuansourinh

Standards Engineering Supervisor
Brett Hanson

Division Director
Bob Risch

2. Application

Composite utility poles have at least two particular applications:

- Back-lot sites where material and tools must be packed in or where it is not economical to employ a large crane to lift material over a home or other structure. Transformer banks and switches should be avoided in back-lot sites.
- Wetlands or other environmentally sensitive areas where the use of treated wood poles should be avoided

30- and 40-ft poles are provided pre-drilled to accommodate a secondary spool insulator angle bracket, Stock No. 690402.

50- and 55-ft poles are provided pre-drilled to accommodate a pole top insulator bracket, stock number 563253, and a secondary spool insulator angle bracket, Stock No. 690402.

60-ft H1 poles are pre-drilled to accommodate equipment and framing attachments for two gains of primary lines, whether in parallel or perpendicular configuration.

Stock No. 014618 is rated for NESC Grade-C H1 (wood pole equivalent) deflection.

The 2007 National Electrical Safety Code (NESC) allows the same Strength Factors to be used as for steel and pre-stressed concrete poles, providing that the composite pole strengths are specified as 5% Lower Exclusion Limit (LEL) values.

Contact the Civil/Structural group for situations where a composite pole will be subjected to heavy vertical or combined (vertical and transverse) loads.

Composite utility poles are typically direct buried.

Jacking lugs, jacking bar assembly kits, and climbing steps are not included with the pole assemblies. Climbing steps for above the first ten feet must be ordered separately, while climbing steps for the first ten feet may be available from the Tool Room. Jacking bar assembly kits and jacking lugs may also be available from the Tool Room.

Design engineers should refer to Table 2 for the recommended number of pole climbing steps to order for a given pole.

Table 2. Climbing Step Counts

Pole Height (ft)	Minimum Number of Climbing Steps	Minimum Number of Climbing Steps Above the First 10 ft
30	16	10
40	24	18
50	30	24
55	34	28
60	38	32

One pole assembly requires four (reusable) jacking lugs or two jacking bars. Climbing steps are permanently installed in pre-drilled holes, one every 15 inches, beginning approximately 10 ft above grade.

Climbing step hole plugs (Stock No. 013177) are installed in locations where climbing steps are not installed, preventing insects from nesting inside the pole. Plugs are removable and reusable. Plugs for the first 10 ft of the pole are included with modular pole assemblies.

Individual pole modules range in weight from 142 to 299 lb.

The manufacturer of this modular composite utility pole system can produce poles of any class up to 120 ft.

Some field drilling is required to assemble modular composite poles. This work requires carbide drill bits available from the Tool Room.

In some cases, 5 ft must be trimmed off the tip end to attain the desired pole length.

3. Industry Standards

Composite utility poles and accessories shall meet the latest revision of the relevant requirements of the following industry standards:

ASCE 104-2003; Recommended Practice for Fiber-Reinforced Polymer Products for Overhead Utility Line Structures

IEEE Std 1307; IEEE Standard for Fall Protection for Electric Utility Transmission and Distribution on Poles and Structures

4. Pole Requirements

Composite utility poles shall be made from ultra-strong polyurethane resin and E-glass fiber.

Composite utility poles shall be ultraviolet-light resistant, suitable for long-term outdoor exposure.

Composite utility poles shall be gray.

For the purpose of this standard, NESC pole classification shall be Grade C.

Poles shall be in accordance with Table 4b.

Each composite utility pole assembly shall consist of:

- Top cap (Figure 4a)
- Top cap fastening screws (self-tapping #8)
- Pole modules
- Pole module joining hardware kit (bolts, blind nuts, and washers) (Figure 4b)
- Base plate (Figure 4c)
- Base plate fastening hardware kit (J-bolts, nuts, and washers) (Figure 4d)
- Jacking lug / jacking bar hole plugs
- Climbing step hole plugs, set of five for first 10 ft of the pole
- Assembly and installation guide in weather-proof, ultraviolet light-resistant envelope

Poles shall be pre-drilled at the factory with climbing step and bracket holes.

Climbing step hole spacing shall be 15 inches \pm 3 inches and begin approximately two feet above grade and end approximately 6-1/2 ft from the tip end.

Climbing step holes shall be drilled on the same plane, 90 degrees apart at the work level of 40 ft and 50 ft poles. The work level for each is defined as shown in Table 4a.

Table 4a. Work Level Distance

Pole Height (ft)	Work Level Distance from Top of Pole
40	6–16.5 ft
50	5–26.5 ft
60	5–26.5 ft

Bracket holes shall be drilled 90 degrees from step holes.

Table 4b shows pole classifications and dimensions.

Bracket hole details shall be according to Table 4c.

Table 4b. Pole Classification and Dimensions (Nominal)

Stock No.	Pole Length (ft)	NESC Class	RStandard Modules	Pole Weight (lb)	Tip Diameter (in)	Base Diameter (in)
013313	30	H1	M1, M2	312	8.21	12.56
013172	40	H2	M1, M2, M3	488	8.78	15.31
013173	50	1	M1L, M2, M3	599	7.71	15.31
013174	55	1	M1, M2, M3, M4	776	8.91	18.27
014618	60	H1	M3, M4, M5-6	1238	12.32	24.83

Table 4c. Bracket Notes

Stock No.	Pole Length (ft)	Bracket Hole Details
013313	30	Figure 4e
013172	40	Figure 4e
013173	50	Figure 4f
013174	55	Figure 4f
014618	60	Figure 4g

Figure 4a. Top Cap



Figure 4b. Pole Module Joining Hardware



Figure 4c. Base Plate



Figure 4d. Base Plate Fastening Hardware



Figure 4e. Bracket Holes, 30-ft and 40-ft Poles

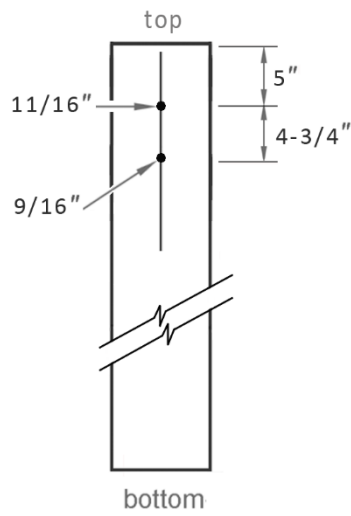

Figure 4f. Bracket Holes, 50-ft and 55-ft Poles

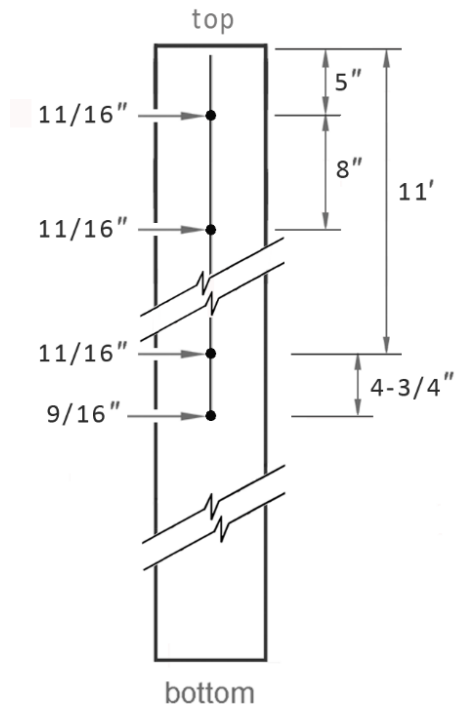
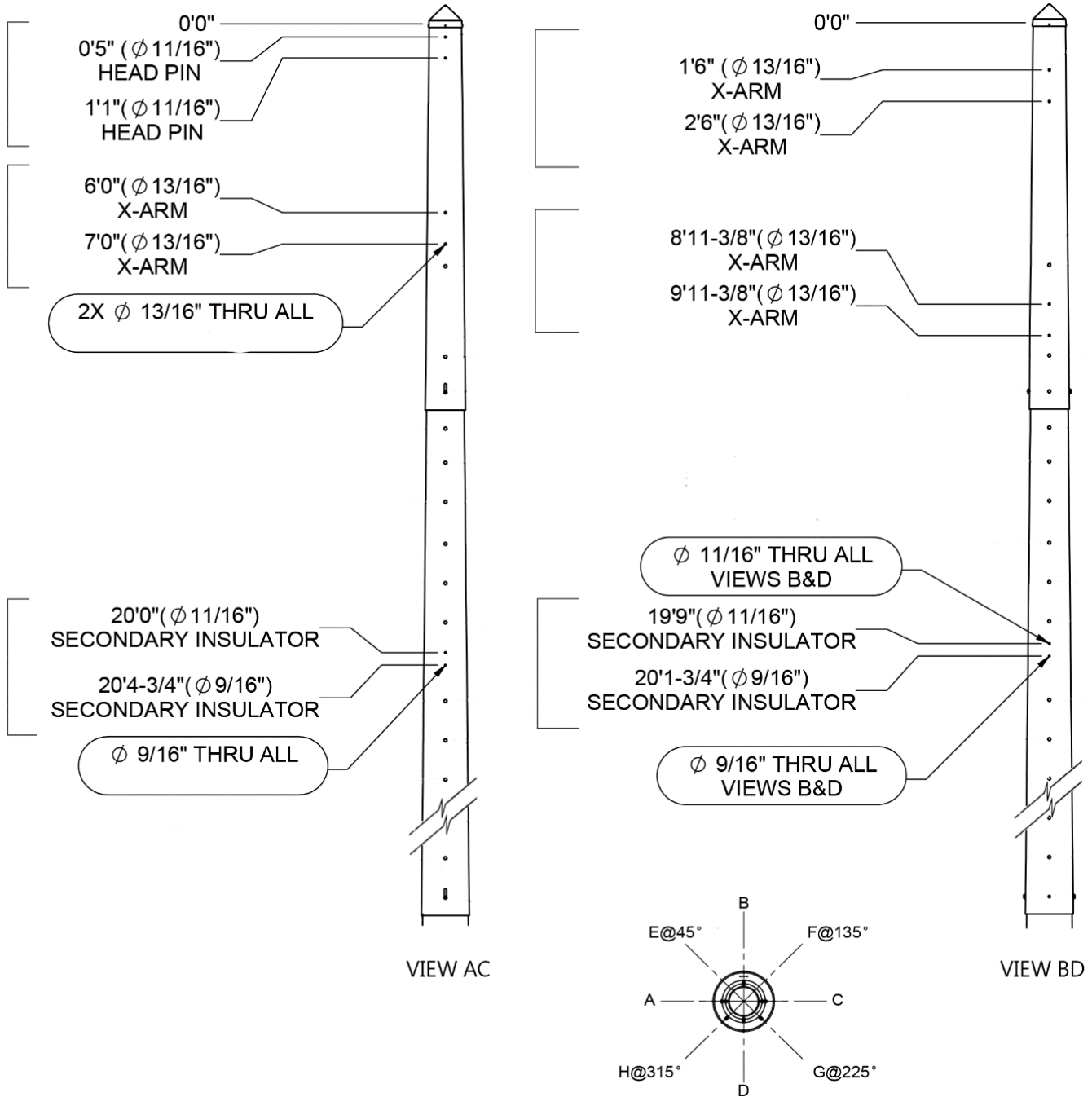

Figure 4g. Bracket Holes, 60 ft



5. Pole Accessories

5.1 Climbing Steps with Fall Arrest

Climbing steps shall:

- Be made of galvanized steel or stainless steel.
- Have a load bearing of 600 lb with no permanent deformation, per NESC Rule 261N
- Have a nominal length of 8-inches
- Fit into a 1-1/8-inch blind hole of the composite pole
- Include a curved washer bracket, hex nut, lock washer or jam nut and fall arrest anchor loop.

Fall arrest anchors shall be rated for 5000 lb, per 7.2.1 of IEEE Standard 1307.

Figure 5.1. Climbing Step with Fall Arrest



5.2 Hole Plugs

Hole plugs shall:

- Be made of high-temperature silicone
- Have a tapered design as shown in Figure 5.2
- Have nominal dimensions as shown in Table 5.2

Figure 5.2. Hole Plug

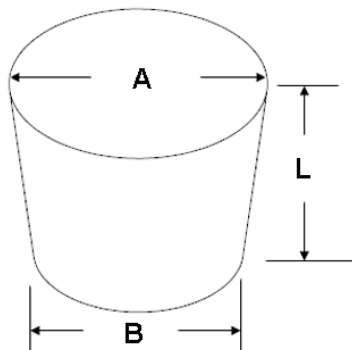

Table 5.2. Hole Plug Dimensions

Stock No.	Description	Dimensions (in)		
		Top Diameter (A)	Bottom Diameter (B)	Length (L)
013177	Plugs for 1-1/8" hole (climbing steps)	1.3	1.0	1.0
014677	Plugs for 13/16" hole (crossarm)	0.9	0.7	1.0
014678	Plugs for 9/16" and 11/16" hole (head pin and secondary insulator)	0.8	0.6	1.0

5.3 Pole Module Joining Hardware Kits

Pole module joining hardware kits shall:

- Be made of galvanized steel
- Include a 3/4-inch diameter, 2-1/2-inch long hex bolt, blind nut, and flat round washer

Figure 5.3. Pole Module Joining Hardware Kit

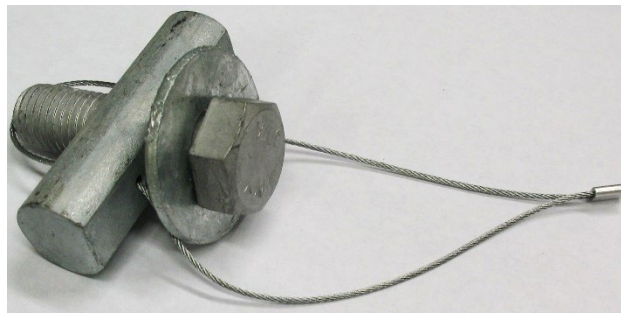

5.4 Jacking Bar Assembly Kit

Jacking bar assembly kits shall include two sets of jacking bar assemblies.

Assemblies shall be rated for use with two (2) sets of two-ton lever chain hoists.

Each jacking bar assembly shall be designed as shown in Figure 5.4.

Assemblies shall include:

- Jacking lug bar (1-in diameter, 42-in long)
- Jacking lug plates
- Retention collar
- Push button quick release pin
- Socket-head screw
- Molex ring tongue terminal
- Galvanized cable

Figure 5.4. Jacking Bar Assembly

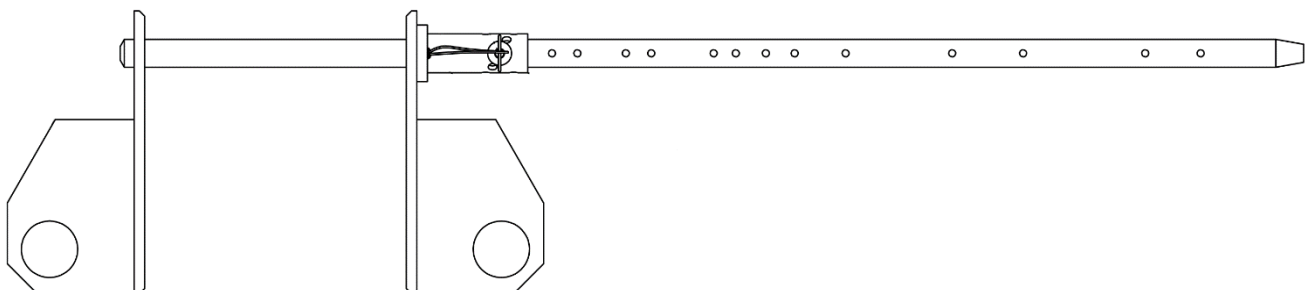

5.5 Single Wall Jacking Lugs

Jacking lugs shall be:

- Made of hot-dipped galvanized steel
- Designed as shown in Figure 5.5
- Stamped with the following:
 - H-JL-S
 - Date of manufacture (DD/MM/YYYY)
 - Country of manufacture

Figure 5.5. Single-Wall Jacking Lug



Jacking lugs are no longer available for purchase.

6. Marking

Each composite pole section shall be permanently and legibly marked with the following information:

- Module number
- Production serial number
- Module weight

Each complete composite pole assembly shall be provided with an aluminum tag containing, but not limited to, the following information:

- Manufacturer
- Length
- Class
- Month/year of manufacture

An aluminum identification tag shall be permanently affixed to the pole at a minimum height of 3 ft above the ground line.

7. Testing and Test Data

Composite pole test data that establishes compliance with the requirements of this material standard shall be provided upon request.

Documentation shall be in English and use customary inch-pound units.

8. Packaging

Each shipping package shall be marked with:

- Manufacturer name
- Seattle City Light purchase order number
- Seattle City Light stock number

Top caps, top cap fastening screws, pole module joining hardware kits, base plates, base plate fastening hardware kits (J-bolts, nuts, and washers), jacking lug hole plugs, climbing step hole plugs, and assembly and installation guide shall be packaged together and labeled for the pole module set to which they belong.

9. Issuance

Unit: EA

10. Approved Manufacturers

Stock No.	Description	RS Technologies Inc.	RS Drawing Number	VAF Industries LLC
013313	30 ft, class H1 assembly	PP-0300-F-0102-C-0000-G-000NC	–	–
013172	40 ft, class H2 assembly	PP-0400-F-0103-C-0000-G-000NC	PP0400F0103C0000-0019, REV A	–
013173	50 ft, class 1 assembly	PP-0500-F-1L03-C-0000-G-000NC	PP0500F1L03C0000-003, REV A	–
013174	55 ft, class 1, assembly	PP-0550-F-0104-C-0000-G-000NC	PP0550F0104C0000-003, REV A	–
014618	60 ft, class H1 assembly	PP-0600-F-0306-C-GY-000	20-BG-0037-CDL-01, REV. A	–
013175*	Jacking lug	–	–	–
013177	Silicone plugs for 1-1/8" hole (climbing step)	100831	–	–
013524	Pole module joining hardware kit	RSK-BN-250-75-GD	–	–
013745	Climbing step with fall arrest	7232	–	1002
014672	Jacking bar assembly kit (M1-M11)	30070	–	–
014677	Silicone plugs for 13/16" hole (crossarm)	100775	–	–
014678	Silicone plugs for 9/16" and 11/16" hole (head pin and secondary insulator)	100774	–	–

Note: Jacking lugs are no longer available for purchase.

11. References

- IEEE C2-2007**; National Electrical Safety Code (NESC); 2007
- National Electrical Safety Code (NESC) Handbook**, 2012 edition

12. Sources

Hodges, Norm; SCL Standards Engineer and subject matter expert for 5088.14

Lu, Curtis; SCL Standards Engineer and subject matter expert for 5088.14

RS Technologies; www.rspoies.com

SCL 5214.14; Composite Utility Poles, Modular” (canceled / renumbered to 5088.14)

Shipek, John; SCL Standards Supervisor, subject matter expert, and originator of 5088.14

Wang, Quan; SCL Standards Engineer and subject matter expert for 5088.14